

FOR THE MEETING OF: August 16, 2018
AGENDA ITEM: 4.a

TO: Historic Landmarks Commission

THROUGH: Lisa Anderson-Ogilvie, AICP, Deputy Community Development Director and Planning Administrator

FROM: Kimberli Fitzgerald, AICP, Historic Preservation Officer

HEARING DATE: August 16, 2018

CASE NO.: Historic Design Review Case No. HIS18-23

APPLICATION SUMMARY: A proposal to add two patios, a metal awning, and rehabilitate the exterior of Allesandro's Restaurant (1870).

LOCATION: 120 Commercial Street NE

REQUEST Major Historic Design Review proposal to add two concrete patios, a metal awning, and rehabilitate the exterior of the Alessandro's Restaurant (1870), a non-contributing resource within the Salem Downtown Historic District, zoned CB (Central Business District), and located at 120 Commercial Street NE / 97301; Marion County Assessors Map and Tax Lot Number 073W27AB08000.

APPLICANT(S): Jim Toporek, Studio 3 Architecture for Scott Chernoff

APPROVAL CRITERIA: Salem Revised Code (SRC) Chapter 230
230.045 Standards for Non-Contributing Buildings and Structures in Commercial Historic Districts
(g) Alterations and Additions

RECOMMENDATION: APPROVE

BACKGROUND

On July 6, 2018, the applicant submitted materials for a Major Historic Design Review for a number of proposed new alterations to the building and site.

Additional materials were submitted on July 25, 2018 and the application was deemed complete for processing on July 26, 2018.

Notice of public hearing was sent by mail to surrounding property owners pursuant to Salem Revised Code (SRC) requirements on July 26, 2018 (**Attachment A**). Public hearing notice was also posted on the property in accordance with the posting provision outlined in SRC 300.620.

The City of Salem Historic Landmarks Commission will hold a public hearing for the case on August 16, 2018 at 5:30 p.m., in Council Chambers, Room 240, located at 555 Liberty Street SE.

The state-mandated 120-day deadline to issue a final local decision, including any local appeals in this case is November 23, 2018, unless an extension is granted by the applicant.

PROPOSAL

The applicant is proposing modifications on the northern, western, and eastern facades of the Alessandro's Restaurant Building. Their full proposal can be found in **Attachment C**; a summary of their proposal is below.

Storefront

The applicant is proposing to replace the existing storefront on the front façade with a new Oldcastle Series 3000 aluminum storefront with a tiled base (Daltile HLO2 Raffia 6" x 6" Ceramic Wall Tiles). The proposed new storefront will be slightly larger than the existing storefront. The existing brick veneer on this façade will be retained and repaired where needed.

Awnings and Patio Covers

The applicant is proposing to install a new profiled metal canopy with under-mounted light fixtures extending across the front façade. Flat profiled metal awnings are proposed for two of the three new door openings on the northern façade. A new wood framed canopy topped with profiled metal roofing is proposed to cover the new patio area located at the western corner of the north façade.

Windows

The applicant is proposing to install fourteen Oldcastle Signature 5' x 6' fixed tripartite aluminum windows trimmed in cedar along the northern façade. No changes are proposed for the windows on the front (west) or rear (east) façades. The glazing within these windows is proposed to be tinted with a Solarban 60 low-e glass.

Doors

The applicant is proposing to replace the front entry door as part of the storefront replacement on the primary (western) façade. Three new double people doors are proposed on the north façade and a new rear people door/alcove is proposed for the eastern façade.

Two glass and metal roll top garage doors are proposed for both the north and eastern facades. The glazing within these doors is proposed to be tinted with Solarban 60 low-e glass. The applicant is proposing to install a tiled base (Daltile HLO2 Raffia 6" x 6" Ceramic Wall Tiles) below the roll top doors on the north façade.

Trees, Cable Railing and Planters

The applicant is proposing to remove three trees adjacent to the north façade and replant three trees. The applicant is proposing to install a 42” high black patio railing and concrete planters of varying heights are proposed around the exterior of the proposed new patios adjacent to the north façade.

SUMMARY OF RECORD

The following items are submitted to the record and are available upon request: All materials submitted by the applicant and any materials and comments from public agencies, City departments, neighborhood associations, and the public; and all documents referenced in this report.

APPLICANT’S STATEMENT

A request for historic design review must be supported by proof that it conforms to all applicable criteria imposed by the Salem Revised Code. The applicants submitted a written statement, which is included in its entirety as **Attachment C** in this staff report.

Staff utilized the information from the applicant’s statements to evaluate the applicant’s proposal and to compose the facts and findings within the staff report. Salem Revised Code (SRC) Chapter 230.045 *Standards for Non-Contributing Buildings and Structures in Commercial Historic Districts (g) Alterations and Additions* are the applicable criteria for evaluation of this proposal.

FACTS & FINDINGS

1. Historic Designation

Under Salem Revised Code (SRC) Chapter 230, no development permit for a designated historic resource shall be issued without the approval of the Historic Landmarks Commission (HLC). The HLC shall approve, conditionally approve, or deny the application on the basis of the projects conformity with the criteria. Conditions of approval, if any, shall be limited to project modifications required to meet the applicable criteria.

According to SRC 230.020(f), historic design review approval shall be granted if the application satisfies the applicable standards set forth in Chapter 230. The HLC shall render its decision supported by findings that explain conformance or lack thereof with relevant design standards, state the facts relied upon in rendering the decision, and explain justification for the decision.

2. Historic Significance

According to nomination documents the Alessandro’s Restaurant Building was constructed in 1870(circa) and is a two story commercial building (**Attachment B**).

Due to significant alterations this resource is historic non-contributing to Salem's Downtown Commercial Historic District. Additional historic research completed by staff indicates that the original structure may have been built as early as 1867, however, there is no evidence that there are any extant features from this early period.

3. Neighborhood and Citizen Comments

The subject property is located within the Central Area Downtown Neighborhood Association (CANDO). Notification of the public hearing was sent to the neighborhood association, all property owners within the Salem Downtown National Register District, and surrounding property owners within 250 feet of the property pursuant to Salem Revised Code (SRC) requirements on July 26, 2018. Notice of public hearing was also posted on the subject property. At the time of writing this staff report, no comments were received from the neighborhood association or from adjoining property owners.

4. City Department and Public Agency Comments

The Building and Safety Division indicates that the applicant must obtain required building permits. The Planning Division requires site plan approval. The Public Works Division has noted that awning permits may be required.

5. Historic Design Review

SRC Chapter SRC 230.045(g) specify the standards applicable to this project. The applicable criteria and factors are stated below in **bold** print. Following each criterion is a response and/or finding relative to the amendment requested.

FINDINGS

Criteria 230.045. Standards for Non-Contributing Buildings and Structures in Commercial Historic Districts.

(g) Alterations and Additions. *Additions and alterations that comply with the standards in this section may be made to historic non-contributing buildings. Whenever practical, additions and alterations to historic non-contributing buildings should result in the restoration of missing features from the period of significance, or the removal of alterations that were made outside of the period of significance.*

(1) Materials.

(A) Materials shall be consistent with those present in buildings in the district generally.

Finding: The applicant is proposing new storefronts, windows, doors and awnings using materials that are consistent with the buildings in the district generally therefore staff recommends that the HLC find that this standard has been met.

(B) Roofing materials shall have a non-reflective, matte finish.

Finding: The applicant is not proposing to replace the main roof on the building. However, the applicant is proposing to install profiled metal roofing materials on the top of the proposed canopy over the patio at the northwest corner that will a non-reflective, matte finish. Staff recommends that the HLC find that this standard has been met.

(2) Design.

(A) The location for an addition shall be at the rear, or on an inconspicuous side, of the building.

Finding: The applicant is not proposing an addition that will increase the square footage or height of the building, therefore staff recommends that the HLC find that this standard is not applicable to the evaluation of this proposal.

(B) Changes to features of a historic non-contributing building that date from the period of significance shall be minimized.

Finding: The property does not retain any significant character defining features from the period of significance. Therefore, staff recommends that the HLC find that this standard has been met.

(C) The design shall be compatible with the character of historic contributing buildings in the historic district and create a harmonious relationship with historic contributing buildings in the district generally. Factors in evaluating the design under this paragraph include, but are not limited to:

(i) Similarities in the size and scale to those used in historic contributing buildings in the district generally.

Finding: The property shall continue to be used as a commercial use, its historic purpose. The height, massing, and building footprint will not be altered. The scale and size of the proposed new openings are compatible with those found within historic contributing buildings within the Downtown Commercial District generally. Staff recommends that the HLC find that this standard has been met.

(ii) Use of architectural features that reflect, or are similar to, the architectural style of historic contributing buildings in the district.

Finding: The applicant's proposal generally uses architectural features that reflect, or are similar to those found on contributing commercial buildings within the District generally. Therefore staff recommends that the HLC find that this standard has been met.

(iii) Simple gable or hipped roofs with a pitch similar to surrounding buildings are generally appropriate. Flat roofs may be appropriate when the prevailing

styles of architecture provide an appropriate context. Exotic or complex roof forms that detract from the visual continuity of the district are generally inappropriate.

Finding: The applicant is not proposing to alter the roof on the building. However, the applicant is proposing a new canopy over the proposed new patio area. This canopy has a slightly cantilevered profiled metal roof supported by a wooden framed structure. This form is compatible with the building and the surrounding Historic District, therefore staff recommends the HLC find that this standard has been met.

(iv) Additions should have a similar mass to surrounding buildings.

Finding: The applicant is not proposing an addition that will increase the building's square footage or height, therefore staff recommends that the HLC find that this standard is not applicable to the evaluation of this proposal.

(v) Front elevations should appear similar in scale to those seen traditionally in the surrounding neighborhood.

Finding: The applicant is not proposing to substantially alter the primary façade of the resource, and the proposed alterations to the north and eastern facades are similar in scale to similar facades found throughout the District. Staff recommends that the HLC find that this standard has been met.

(vi) The width and height of the addition should not exceed the typical dimensions seen in the district.

Finding: The applicant is not proposing an addition increasing the building's square footage or height, therefore staff recommends that the HLC find that this standard is not applicable to the evaluation of this proposal.

(vii) Simple rectangular building forms are generally preferred.

Finding: The resource will retain its rectangular building form, therefore staff recommends that the HLC find that this standard has been met.

(D) The design shall make clear what is original and what is new.

Finding: The applicant's design is compatible with the resource and is not a reconstruction based upon historic evidence. The utilization of the modern glass and metal garage doors on both the north and east facades and the metal trim above the central entry on the north façade ensure that it is clear what is original and what is new. Staff recommends that the HLC find that this standard has been met.

(E) Features that have been added over time and have attained significance in their own right shall be preserved, even if the features do not reflect the period of significance.

Finding: There are no significant features that have acquired significance over time. Staff recommends that the HLC find that this standard is not applicable to the evaluation of this proposal.

(F) An addition that adds stories shall increase the height of a building to no more than four stories.

Finding: The applicant is not proposing to add an addition increasing the square footage or height, therefore staff recommends that the HLC find that this standard is not applicable to the evaluation of this proposal.

RECOMMENDATION

Based upon the information presented in the application, plans submitted for review, and findings as presented in this staff report, staff recommends that the Historic Landmarks Commission **APPROVE** the proposal.

DECISION ALTERNATIVES

1. APPROVE the proposal as submitted by the applicant and indicated on the drawings.
2. APPROVE the proposal with conditions to satisfy specific standard(s).
3. DENY the proposal based on noncompliance with identified standards in SRC 230, indicating which standard(s) is not met and the reason(s) the standard is not met.

Attachments: A. Hearing Notice and Vicinity Map
B. Excerpt from National Register Historic Resource Documents
C. Applicant's Submittal Materials

Prepared by Kimberli Fitzgerald, Historic Preservation Officer



HEARING NOTICE

LAND USE REQUEST AFFECTING THIS AREA

Audiencia Pública

Si necesita ayuda para comprender esta informacion, por favor llame 503-588-6173

CASE NUMBER:	Historic Design Review Case No.HIS18-23
AMANDA APPLICATION NO:	18-114404-DR
HEARING INFORMATION:	<u>Historic Landmarks Commission, Thursday, August 16, 2018, 5:30 P.M., Council Chambers, Room 240, Civic Center, 555 Liberty St SE, Salem, OR 97301</u>
PROPERTY LOCATION:	120 Commercial Street NE, Salem, OR 97301
OWNER(S):	Scott Chernoff for CH Reed LLC
APPLICANT / AGENT(S):	Jim Toporek, Studio 3 Architecture
DESCRIPTION OF REQUEST:	<p>Summary: A proposal to add two patios, a metal awning, and rehabilitate the exterior of Allesandro's Restaurant (1870).</p> <p>Request: Major Historic Design Review proposal to add two concrete patios, a metal awning, and rehabilitate the exterior of the Allesandro's Restaurant (1870), a non-contributing resource within the Salem Downtown Historic District, zoned CB (Central Business District), and located at 120 Commercial Street NE / 97301; Marion County Assessors Map and Tax Lot Number 073W27AB08000.</p>
CRITERIA TO BE CONSIDERED:	<p><u>MAJOR HISTORIC DESIGN REVIEW</u></p> <p>230.045. Standards for Non-Contributing Buildings and Structures in Commercial Historic Districts.</p> <p>(g) Alterations and Additions. Additions and alterations that comply with the standards in this section may be made to historic non-contributing buildings. Whenever practical, additions and alterations to historic non-contributing buildings should result in the restoration of missing features from the period of significance, or the removal of alterations that were made outside of the period of significance.</p> <p>(1) Materials.</p> <p>(A) Materials shall be consistent with those present in buildings in the district generally.</p> <p>(B) Roofing materials shall have a non-reflective, matte finish.</p> <p>(2) Design.</p> <p>(A) The location for an addition shall be at the rear, or on an inconspicuous side, of the building.</p> <p>(B) Changes to features of a historic non-contributing building that date from the period of significance shall be minimized.</p> <p>(C) The design shall be compatible with the character of historic contributing buildings in the historic district and create a harmonious relationship with historic contributing buildings in the district generally. Factors in evaluating the design under this paragraph include, but are not limited to:</p> <p>(i) Similarities in the size and scale to those used in historic contributing buildings in the district generally.</p> <p>(ii) Use of architectural features that reflect, or are similar to, the architectural style of historic contributing buildings in the district.</p> <p>(iii) Simple gable or hipped roofs with a pitch similar to surrounding buildings are generally appropriate. Flat roofs may be appropriate when the prevailing styles of architecture provide an appropriate context. Exotic or complex roof forms that detract from the visual continuity of the district are generally inappropriate.</p>

- (iv) Additions should have a similar mass to surrounding buildings.
- (v) Front elevations should appear similar in scale to those seen traditionally in the surrounding neighborhood.
- (vi) The width and height of the addition should not exceed the typical dimensions seen in the district.
- (vii) Simple rectangular building forms are generally preferred.
- (D) The design shall make clear what is original and what is new.
- (E) Features that have been added over time and have attained significance in their own right shall be preserved, even if the features do not reflect the period of significance.
- (F) An addition that adds stories shall increase the height of a building to no more than four stories.

HOW TO PROVIDE TESTIMONY:

Any person wishing to speak either for or against the proposed request may do so in person or by representative at the Public Hearing. Written comments may also be submitted at the Public Hearing. Include case number with the written comments. Prior to the Public Hearing, written comments may be filed with the Salem Planning Division, Community Development Department, 555 Liberty Street SE, Room 305, Salem, Oregon 97301. Only those participating at the hearing, in person or by submission of written testimony, have the right to appeal the decision.

HEARING PROCEDURE:

The hearing will be conducted with the staff presentation first, followed by the applicant's case, neighborhood organization comments, testimony of persons in favor or opposition, and rebuttal by the applicant, if necessary. The applicant has the burden of proof to show that the approval criteria can be satisfied by the facts. Opponents may rebut the applicant's testimony by showing alternative facts or by showing that the evidence submitted does not satisfy the approval criteria. Any participant may request an opportunity to present additional evidence or testimony regarding the application. A ruling will then be made to either continue the Public Hearing to another date or leave the record open to receive additional written testimony.

Failure to raise an issue in person or by letter prior to the close of the Public Hearing with sufficient specificity to provide the opportunity to respond to the issue, precludes appeal to the Land Use Board of Appeals (LUBA) on this issue. A similar failure to raise constitutional issues relating to proposed conditions of approval precludes an action for damages in circuit court.

Following the close of the Public Hearing a decision will be issued and mailed to the applicant, property owner, affected neighborhood association, anyone who participated in the hearing, either in person or in writing, and anyone who requested to receive notice of the decision.

CASE MANAGER:

Kimberli Fitzgerald, Case Manager, City of Salem Planning Division, 555 Liberty Street SE, Room 305, Salem, Oregon 97301. Telephone: 503-540-2397; E-mail: kfitzgerald@cityofsalem.net.

NEIGHBORHOOD ORGANIZATION:

Central Area Neighborhood Development Organization (CAN-DO), Bruce Hoffman, Land Use Chair; Phone: (503) 781-8542; Email: bruhof@gmail.com

DOCUMENTATION AND STAFF REPORT:

Copies of the application, all documents and evidence submitted by the applicant are available for inspection at no cost at the Planning Division office, City Hall, 555 Liberty Street SE, Room 305, during regular business hours. Copies can be obtained at a reasonable cost. The Staff Report will be available seven (7) days prior to the hearing, and will thereafter be posted on the Community Development website:

www.cityofsalem.net/notices

ACCESS:

The Americans with Disabilities Act (ADA) accommodations will be provided on request.

NOTICE MAILING DATE:

July 26, 2018

PLEASE PROMPTLY FORWARD A COPY OF THIS NOTICE TO ANY OTHER OWNER, TENANT OR LESSEE.

For more information about Planning in Salem:

<http://www.cityofsalem.net/planning>

It is the City of Salem's policy to assure that no person shall be discriminated against on the grounds of race, religion, color, sex, marital status, familial status, national origin, age, mental or physical disability, sexual orientation, gender identity and source of income, as provided by Salem Revised Code Chapter 97. The City of Salem also fully complies with Title VI of the Civil Rights Act of 1964, and related statutes and regulations, in all programs and activities. Disability-related modification or accommodation, including auxiliary aids or services, in order to participate in this meeting or event, are available upon request. Sign language and interpreters for languages other than English are also available upon request. To request such an accommodation or interpretation, contact the Community Development Department at 503-588-6173 at least three business days before this meeting or event.





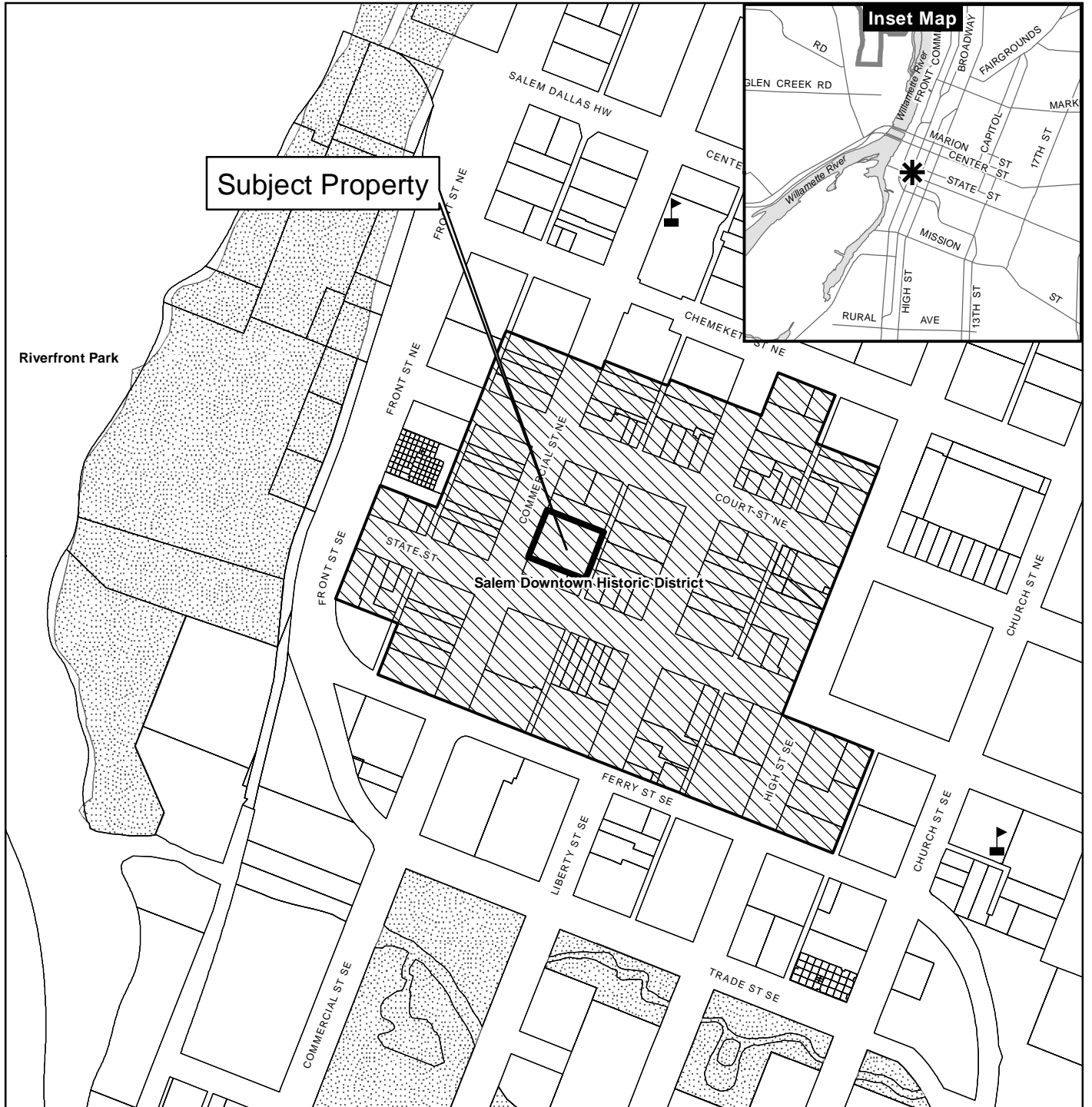

TTD/TTY telephone 503-588-6439 is also available 24/7

Vicinity Map

120 Commercial St NE



Legend

-  Taxlots
-  Urban Growth Boundary
-  City Limits
-  Outside Salem City Limits
-  Historic District
-  Schools
-  Parks



0 100 200 400 Feet



This product is provided as is, without warranty. In no event is the City of Salem liable for damages from the use of this product. This product is subject to license and copyright limitations and further distribution or resale is prohibited.

United States Department of the Interior
National Park Service

National Register of Historic Places

Continuation Sheet

Section number: 7 Salem Downtown Historic District

120 Commercial Street, NE

Classification: Historic Non-Contributing

Historic Name: Unknown

Current Name(s): Alessandro's Restaurant

Year of Construction: c.1870; 1990

Legal Description: 073W27AB08000; Salem Addition, from Lots 5, 6 & 7, Block 33

Owner(s): Fasani, LLC
120 Commercial Street, NE
Salem, Oregon 97301

Description: This is a two-story commercial building. The date of construction may have been as early as c.1870. The Sanborn maps show that Durbin's Livery was at this location in 1884; Minto & Lowe Livery in 1888; a hardware and stove shop in 1890; YMCA Rooms in 1895; and an electric painting company and photo shop in 1926. Substantial changes have occurred to the building and the latest remodeling appears to have occurred in the 1990s. The current facade has brick veneer on the first one-and-one-half stories and is stucco-covered above. Windows are arched and fixed. The building does not contribute to the character of the district in its current condition.

Historic Building Report

Kirsten Straus, City of Salem Historic Perseveration Intern

July 2018

120 Commercial St NE, Durbin Bros.
Livery

The Durbin Brothers (Solomon and C.J., and later Isaac) had a livery at this corner as early as 1853. In 1867, the livery burned down and the brothers elected to build a new one at the same spot. They built a whole brick block, including a new livery, which the local newspaper referred to as Durbin's Block.

The brothers operated the livery (located at 120 Commercial St) until the 1870s. The block was divided and different owners modernized the buildings until they no longer resembled each other. This section was the original livery. In the 1890s, the livery moved and the building housed a hardware store. In 1892, the YMCA raised the roofline and remodeled the top portion of the old livery as rooms. In the remodel, the facade of the building was drastically altered. In 1908, The Salem Hardware Company moved into the first floor. A string of owners operated this business at this location

until 1961. In 1946, the owners of the building removed the facade erected for the YMCA remodel and again significantly altered the building. In 1962, the building is again remodeled in the international

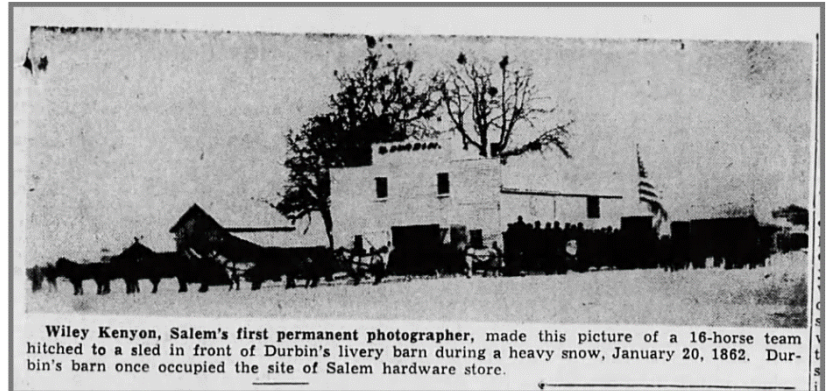

DCJ, Feb. 3, 1947

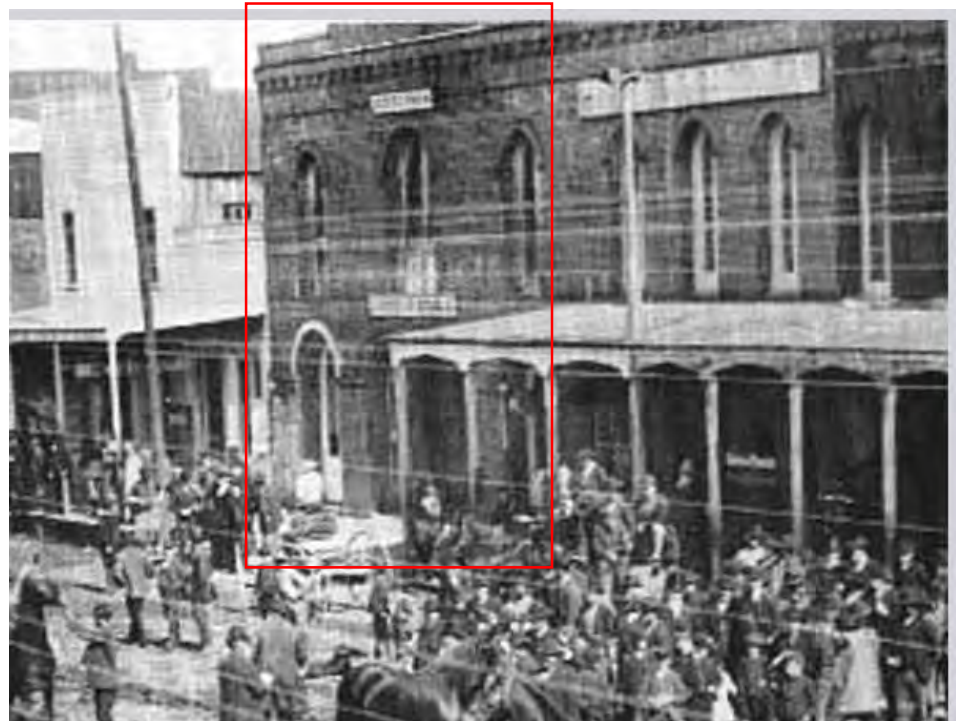

Original Façade - Durbin Bros. Block, Livery just right of white building, "Horse Fair on Commercial St" 1880s (SPL, SJ828)

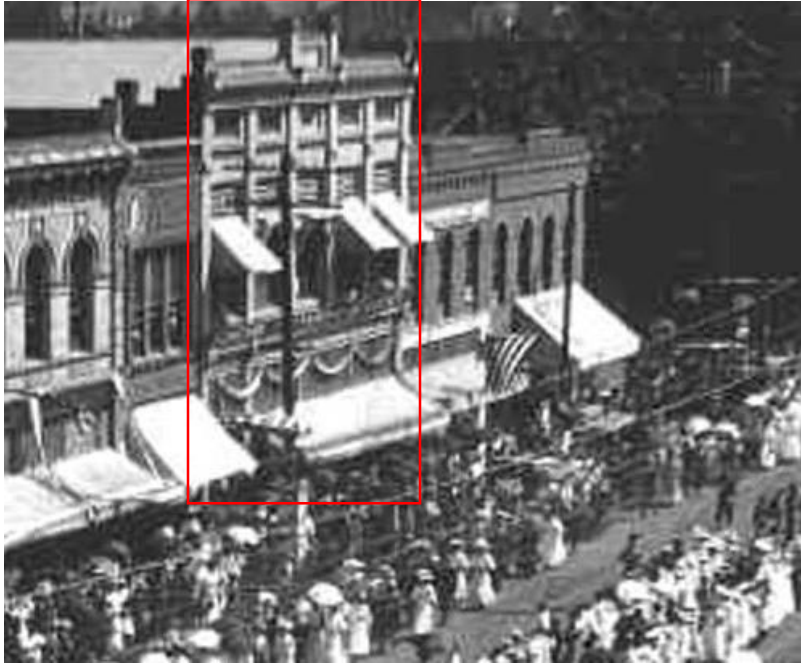

YMCA Façade - Memorial Day celebration on Commercial Street in Salem, Oregon, 1904 (SPL, SJ822)

style. The building now most resembles the facade found in the 1946 remodel, after the building went through another significant remodel in 1990 to prepare the space for its role as the home of the Willamette Brew Pub.



YMCA Facade, 1939 (SPL, 1371)



1946 Remodel (SPL, SJ188)



1962 Remodel (SJ, April 11, 1962)



Historic Landmarks Commission Application

120 Commercial St.
Salem, OR 97301

SRC 230.020:

1.

- (A) The addition of awnings and openings to a non-contributing building in a commercial historic district requires Historic Landmarks Commission approval.

SRC 230.045:

- (a) Materials will be re-paired and painted but not replaced
- (b) Windows will be replaced at the ground floor level at the western façade. These existing windows are not from the period of significance. They will be replaced with a storefront assembly and will bring the appearance of those windows closer to the period of significance.
- (c) A door will be replaced at the ground floor level at the western façade. The existing door is not from the period of significance. It will be replaced with a storefront assembly and will bring the appearance of that door closer to the period of significance.
- (d) See items SRC 230.045 for storefront items.
- (e) No roofing is being replaced.
- (f) No lintels, architraves, sills and other architectural details are being replaced.
- (g) Alterations and additions. Additions and alterations that comply with the standards in this section may be made to historic non-contributing buildings. Whenever practical, additions and alterations to historic non-contributing buildings should result in the restoration of missing features from the period of significance, or the removal of alterations that were made outside of the period of significance.***

(1) Materials.

(A) Materials shall be consistent with those present in buildings in the district generally.

Aluminum windows and metal awnings are common in the downtown historic district. The new proposed openings will match the color and glazing of the existing fenestrations.

(B) Roofing materials shall have a non-reflective, matte finish.

The building's roof will not be affected by the work. The metal roofing proposed for the new covers will be of a non-reflective, matte finish.

(2) Design.

(A) The location for an addition shall be at the rear, or on an inconspicuous side, of the building.

There will be no building addition. Work beyond the existing planes of the exterior walls includes new awnings, a canopy and hardscaping.

(B) Changes to features of a historic non-contributing building that date from the period of significance shall be minimized.

The historical features from the period of significance are no longer evident on the façade. No proposed work will detract from that period of significance.

(C) The design shall be compatible with the character of historic contributing buildings in the historic district and create a harmonious relationship with historic contributing buildings in the district generally. Factors in evaluating the design under this subsection include, but are not limited to:

(i) Similarities in the size and scale to those used in historic contributing buildings in the district generally.

The proposed openings are typical of structures in the historic district. The new windows consist of single aluminum windows with mullions that simulate vertically oriented, three-gang windows typical of the historic district. The proposed awnings mimic the appearance and scale of those typical of the district. The rollup doors play off of the more recent alley improvements in the immediate vicinity of the site.

(ii) Use of architectural features that reflect, or are similar to, the architectural style of historic contributing buildings in the district.

See above. Additionally, wood frames wrap the new windows in a format that is typical of windows in the historic district.

(iii) Simple gable or hipped roofs with a pitch similar to surrounding buildings are generally appropriate. Flat roofs may be appropriate when the prevailing styles of architecture provide an appropriate context. Exotic or complex roof forms that detract from the visual continuity of the district are generally inappropriate.

This item is not applicable to the project.

(iv) Additions should have a similar mass to surrounding buildings.

This item is not applicable to the project.

(v) Front elevations should appear similar in scale to those seen traditionally in the surrounding neighborhood.

The front elevation is receiving ground level storefront glazing and a new awning. These elements bring the front façade closer to the character of the surrounding historic district and closer to the building's façade at the period of significance.

(vi) The width and height of the addition should not exceed the typical dimensions seen in the district.

This item is not applicable to the project.

(vii) Simple rectangular building forms are generally preferred.

This item is not applicable to the project.

(D) The design shall make clear what is original and what is new.

Features from the period of significance are not distinguishable on the existing façade.

(E) Features that have been added over time and have attained significance in their own right shall be preserved, even if the features do not reflect the period of significance.

The upper levels of the front façade will receive paint but will not be altered. The curved forms of the upper windows and the building opening at the entrance have been retained. The commercial street facing, ground floor opening sizes will be retained.

(F) An addition that adds stories shall increase the height of a building to no more than four stories.

This item is not applicable to the project.

(h) No accessibility modifications will be made to the building exterior

(i) All new glazing and doors will meet the current energy codes.

(j) A trash enclosure will be added to the parking area, completely detached from the building.

(k) Awnings and Canopies

-Two concrete patios will be added to the north side of the building for tenant use. A wood canopy will be provided at the northwest corner of the building. The canopy will be constructed of wood with a standing seam metal roof.

-Metal awnings will be provided above the right-of-way along Commercial Street and above the entries along the northern façade. These will be constructed of metal to match the character of the downtown historic district.

Historic Alteration Review - General Resource Worksheet

Site Address: 120 Commercial St. NE Resource Status: Contributing
 Individual Landmark Non- Contributing

Type of Work Activity Proposed

Major Minor

Replacement, Alteration, Restoration or Addition of:

Architectural Feature:

- Deck
- Door
- Exterior Trim
- Porch
- Roof
- Siding
- Window(s) Number of windows: 14
- Other architectural feature (describe) _____

Landscape Feature:

- Fence
- Retaining wall
- Other Site feature
- Streetscape

New Construction:

- Addition
- New Accessory Structure
- Sign
- Awning

Will the proposed alteration be visible from any public right-of-way? YES NO

Project's Existing Material: Painted concrete, brick Project's _____ New No change Material: _____

Project Description

Briefly provide an overview of the type of work proposed. Describe how it meets the applicable design criteria in SRC Chapter 230. Please attach any additional information (i.e., product specification sheets) that will help Staff and the HLC clearly understand the proposed work:

- The building exterior will be patched and re-painted. Some minor wood trim work will occur.
- Window and door openings will be added on the north and eastern facades. Storefront glazing will replace the single pane glazing and wood door on the western facade.
- Two concrete patios will be added to the north side of the building for tenant use. A wood canopy will be provided at the northwest corner of the building.
- Metal awnings will be provided above the right-of-way along Commercial Street and above the entries along the northern facade.
- A concrete walk will be added along the northern side of the building for pedestrian traffic.

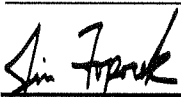
Signature of Applicant

7/5/2018
Date Submitted/Signed



Historic Landmarks Commission Application
Material Specifications
120 Commercial St.
Salem, OR 97301

Paint

1. Sherwin Williams - 2813 Downing Straw – See Keynote 1 on exterior elevations
2. Sherwin Williams - 2824 Renwick Golden Oak – See Keynote 7 on exterior elevations
3. Sherwin Williams - 2803 Rookwood Terra Cotta– See Keynote 8 on exterior elevations
4. Sherwin Williams - 2883 Roycroft Vellum for window trim.

Windows

OldCastle Signature 12PL aluminum windows. 2 ¼" wide outside frame with 2 7/8" vertical mullions. Fixed windows. Finish to match existing windows at front and rear of the building. See window/door elevations for sizes.

Storefront

OldCastle Series 3000 Thermal MultiPlane aluminum storefront. 2"x4-1/2" frame and mullions. Front set. Factory painted Kynar 500 finish to match existing window frames at front and rear of the building.

Storefront Doors to be consistent with Series 3000. See window/door elevations for sizes. Hardware color to match framing.

Glazing

Solarban 60 (2) Clear + Clear. VLT 70, SHGC .39

Awning/Wood Canopy Roofing

Taylor Metal Products HR 34. 1-3/4" spacing for corrugations. Color: Charcoal Gray.

Misc. Metal Products

The color for all flashings and powder coated structural steel is to match the metal roofing color

Hollow Metal Door

Fully welded metal frame and insulated metal 3'-0" x 7'-0" door at alley side of building. Paint to match flashing and metal roofing.

Sectional Doors

Wayne Dalton Aluminum Full View Sectional Doors at patio. Aluminum panel fill at alley side only. 2" Wide framing sections. See window/door elevations for sizes.

Wall Tile

Daltile - HLO2 Raffia 6"X6" Ceramic Wall Tiles.

Window Trim

Cedar 1x4 Wood Trim all sides of the window. Cedar 1x2 horizontally oriented mounted above the top trim. Paint finish all.



BY A PROFESSIONAL ARCHITECT AS SHOWN ON THIS SEAL, THE ARCHITECT ASSURES THAT THE DESIGN AND CONSTRUCTION OF THE WORK SHOWN IN THIS DOCUMENT IS IN ACCORDANCE WITH THE PROFESSIONAL STANDARDS AND ETHICS OF THE ARCHITECTURAL PROFESSION. THE ARCHITECT DOES NOT WARRANT THE ACCURACY OF ANY INFORMATION OR DATA OBTAINED FROM ANY SOURCE OTHER THAN THAT SHOWN ON THIS SEAL.

PROJECT # 2018-012
DATE: 7/5/2018

REVISIONS

BUILDING IMPROVEMENTS FOR:
120 COMMERCIAL ST. NE
SALEM, OREGON 97301



COMMERCIAL STREET LOOKING NORTH FROM CORNER OF STATE ST. IN SALEM, OREGON, 1939



BUILDING PERSPECTIVE - VIEW FROM COMMERCIAL STREET LOOKING EAST



IN THE STATE OF OREGON, I, THE UNDERSIGNED, ROBERT J. ...
REGISTERED ARCHITECT, NO. 4449, DO HEREBY CERTIFY THAT THE ...
DRAWINGS AND SPECIFICATIONS ACCOMPANYING THESE PLANS ...
WERE PREPARED BY ME OR UNDER MY CLOSE PERSONAL SUPERVISION ...
AND THAT I AM A LICENSED ARCHITECT IN THE STATE OF OREGON.

PROJECT # 2018-012
DATE: 7/5/2018

REVISIONS

BUILDING IMPROVEMENTS FOR:
120 COMMERCIAL ST. NE
SALEM, OREGON 97301



SITE PERSPECTIVE - VIEW FROM COMMERCIAL STREET



THIS SEAL IS VALID FOR THE ARCHITECT'S CURRENT LICENSE AND IS NOT VALID FOR THE ARCHITECT'S PREVIOUS OR FUTURE LICENSES. THE ARCHITECT'S LICENSE IS NOT VALID FOR THE ARCHITECT'S PREVIOUS OR FUTURE LICENSES. THE ARCHITECT'S LICENSE IS NOT VALID FOR THE ARCHITECT'S PREVIOUS OR FUTURE LICENSES.

PROJECT # 2018-012
DATE: 7/5/2018

REVISIONS

BUILDING IMPROVEMENTS FOR:
120 COMMERCIAL ST. NE
SALEM, OREGON 97301

SHEET:

HLC 7



BUILDING PERSPECTIVE - VIEW FROM PARKING AREA LOOKING SOUTH



IN THE EVENT CONFLICTS ARE DISCOVERED BETWEEN THE ORIGINAL SIGNED AND SEALED DOCUMENTS PREPARED BY THE ARCHITECTS AND/OR THEIR CONSULTANTS, AND ANY COPY OF THE DOCUMENTS TRANSMITTED BY MAIL, FAX, ELECTRONICALLY OR OTHERWISE, THE ORIGINAL SIGNED AND SEALED DOCUMENTS SHALL GOVERN.

PROJECT # 2018-012
DATE: 7/5/2018

REVISIONS

BUILDING IMPROVEMENTS FOR:
120 COMMERCIAL ST. NE
SALEM, OREGON 97301



BUILDING PERSPECTIVE - VIEW FROM ALLEY LOOKING SOUTHWEST



IN THE EVENT CONFLICTS ARE DISCOVERED BETWEEN THE ORIGINAL SIGNED AND SEALED DOCUMENTS PREPARED BY THE ARCHITECTS AND/OR THEIR CONSULTANTS, AND ANY COPY OF THE DOCUMENTS TRANSMITTED BY MAIL, FAX, ELECTRONICALLY OR OTHERWISE, THE ORIGINAL SIGNED AND SEALED DOCUMENTS SHALL GOVERN.

PROJECT # 2018-012
DATE: 7/5/2018

REVISIONS

BUILDING IMPROVEMENTS FOR:
120 COMMERCIAL ST. NE
SALEM, OREGON 97301



IN THE EVENT CONFLICTS ARE DISCOVERED BETWEEN THE ORIGINAL SIGNED AND STAMPED DOCUMENTS PREPARED BY THE ARCHITECT AND/OR HIS CONSULTANTS, AND ANY COPY OR REPRODUCTION OF THE DOCUMENTS TRANSMITTED BY MAIL, FAX, ELECTRONICALLY OR OTHERWISE, THE ORIGINAL SIGNED AND STAMPED DOCUMENTS SHALL PREVAIL.

PROJECT # 2018-012
DATE: 7/5/2018

REVISIONS

ELEVATION NOTES:

- 1 EXTERIOR FINISH TO REMAIN, PATCH AND PAINT. COLOR: SW 2813 DOWNING STRAW
- 2 PATIO/PLANTER ADDITION. COVERED WITH PERMANENT STRUCTURE
- 3 NEW OPENING AND WINDOW.
- 4 NEW OPENING WITH OVERHEAD GLASS DOOR.
- 5 NEW OPENING WITH STOREFRONT GLAZING.
- 6 NEW METAL CANOPY WITH UNDERMOUNTED LIGHT FIXTURES.
- 7 EXTERIOR FINISH TO REMAIN, PATCH AND PAINT. COLOR: 2824 RENWICK GOLDEN OAK.
- 8 EXTERIOR FINISH TO REMAIN, PATCH AND PAINT. COLOR: 2803 ROOKWOOD TERRA COTTA.
- 9 EXISTING WINDOW TO REMAIN.
- 10 NEW STOREFRONT TO REPLACE EXISTING.
- 11 CABLE RAILING WITH WOOD LEDGE ABOVE.
- 12 EXISTING BRICK TO REMAIN, REPAIR AS REQUIRED.
- 13 NEW ALCOVE.
- 14 PROPOSED SIGNAGE LOCATION, FINAL DESIGN TBD.
- 15 PROPOSED LIGHT FIXTURE LOCATION, PROVIDE POWER.
- 16 4x6 METAL CLAD, WOOD FRAME AROUND ENTRY.

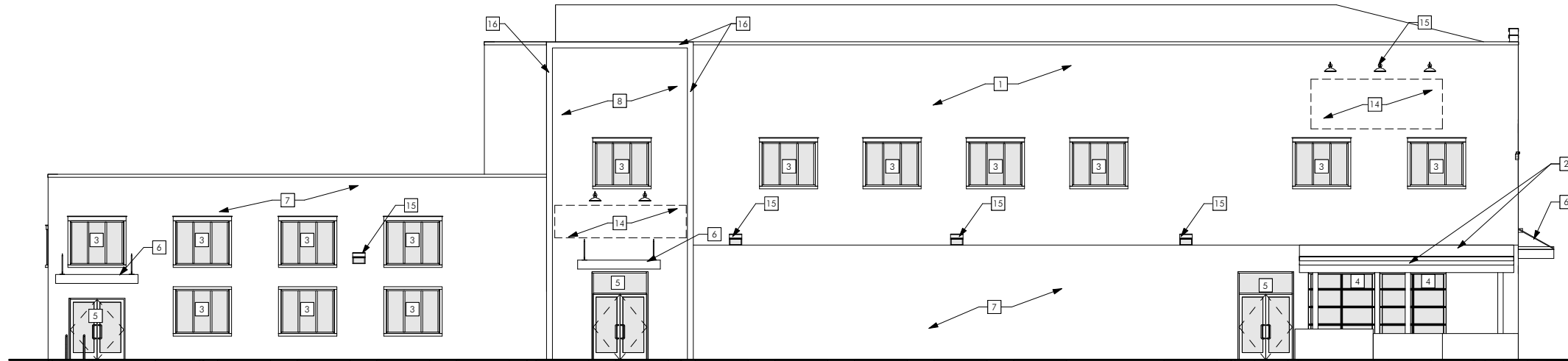

1 NORTH ELEVATION
0' 2' 4' 8' 16' 24' 1/8" = 1'-0"

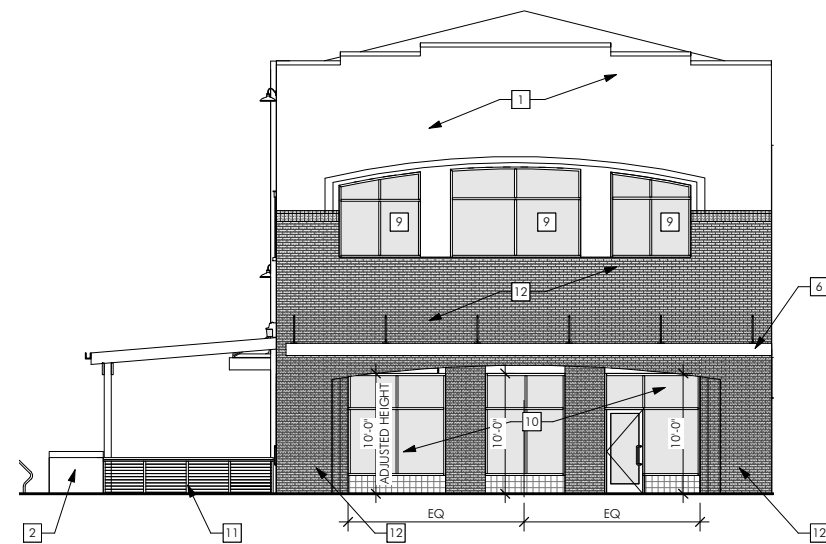

2 WEST ELEVATION
0' 2' 4' 8' 16' 24' 1/8" = 1'-0"

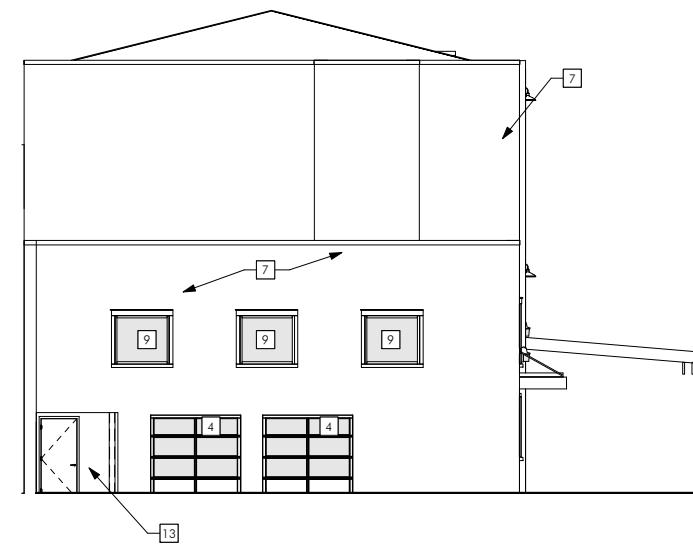

3 EAST ELEVATION
0' 2' 4' 8' 16' 24' 1/8" = 1'-0"

BUILDING IMPROVEMENTS FOR:
120 COMMERCIAL ST. NE
SALEM, OREGON 97301

SHEET:

HLC 4

SITE AREA CALCULATIONS:

BUILDING FOOTPRINT: 6,828 SF
TOTAL SITE AREA: 23,054 SF
PARKING SPACES REQUIRED: 0
43 SPACES PROVIDED INCLUDING TWO ACCESSIBLE PARKING SPACES

SITE PLAN NOTES:

- 1 EXISTING PARKING TO REMAIN.
- 2 RE-STRIPE EXISTING SPACES FROM FULL SIZE PARKING STALLS TO COMPACT PARKING STALLS.
- 3 RE-STRIPE ADA PARKING STALLS, PROVIDE ACCESSIBLE STRIPING AND SIGNAGE. RAMP TO NEW SIDEWALK.
- 4 RE-STIPED COMPACT SPACES PER PLAN.
- 5 NEW SIDEWALK.
- 6 EXTEND EXISTING PLANTER ALONG COMMERCIAL STREET.
- 7 NEW CONCRETE PATIO AREA WITH PLANTERS AND SEATING.
- 8 RE-STRIPE FULL-SIZE PARKING STALLS PER PLAN.
- 9 NEW BIKE PARKING RACKS.
- 10 EXISTING TREE TO REMAIN, VERIFY LOCATION IN FIELD.
- 11 EXISTING CURB CUT TO REMAIN.
- 12 PARKING AREA AT ADJACENT PROPERTY SHOWN FOR REFERENCE ONLY.
- 13 NEW TRASH ENCLOSURE.
- 14 PROPERTY LINE.
- 15 EXISTING TRANSFORMER TO REMAIN.
- 16 ACCESSIBLE CURB RAMP.
- 17 NEW CANOPY OVERHEAD.
- 18 NEW TREE. GREENSPIRE LINDEN / TILIA CORDATA 'GREENSPIRE'. 2" CALIPER.

SITE PLAN LEGEND:

- BUILDING AREA
- LANDSCAPING
- CONCRETE SIDEWALK/PAD

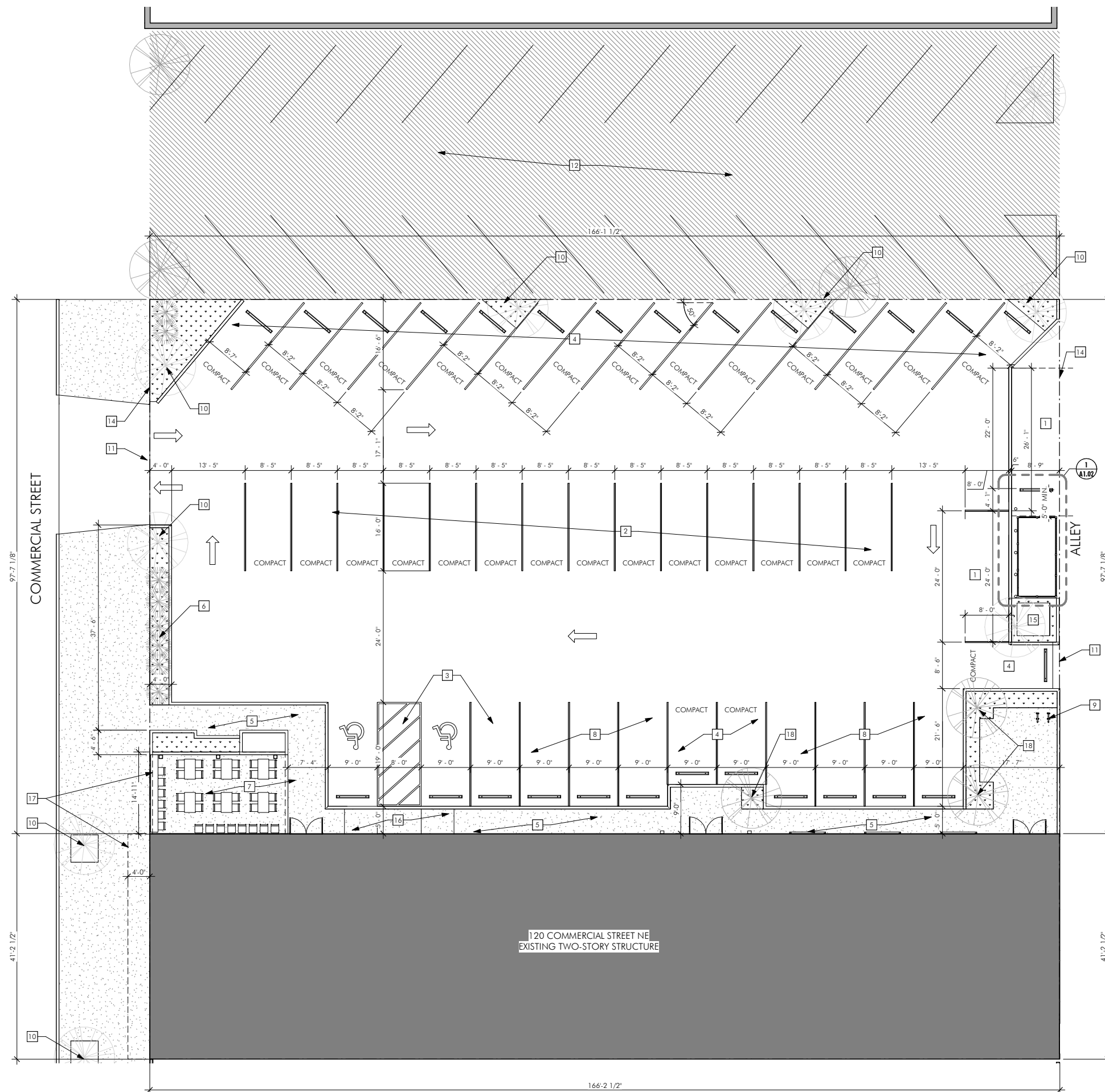

1 SITE PLAN - PROPOSED
0 5 10 20 30 1" = 10'-0"





IN THE EVENT CONFLICTS ARE DISCOVERED BETWEEN THE ORIGINAL SIGNED AND SEALED DOCUMENTS PREPARED BY THE ARCHITECTS AND/OR THEIR CONSULTANTS, AND ANY COPY OF THE DOCUMENTS TRANSMITTED BY MAIL, FAX, ELECTRONICALLY OR OTHERWISE, THE ORIGINAL SIGNED AND SEALED DOCUMENTS SHALL GOVERN.

PROJECT # 2018-012
DATE: 7/5/2018

REVISIONS

BUILDING IMPROVEMENTS FOR:
120 COMMERCIAL ST. NE
SALEM, OREGON 97301

SHEET:
EX.0

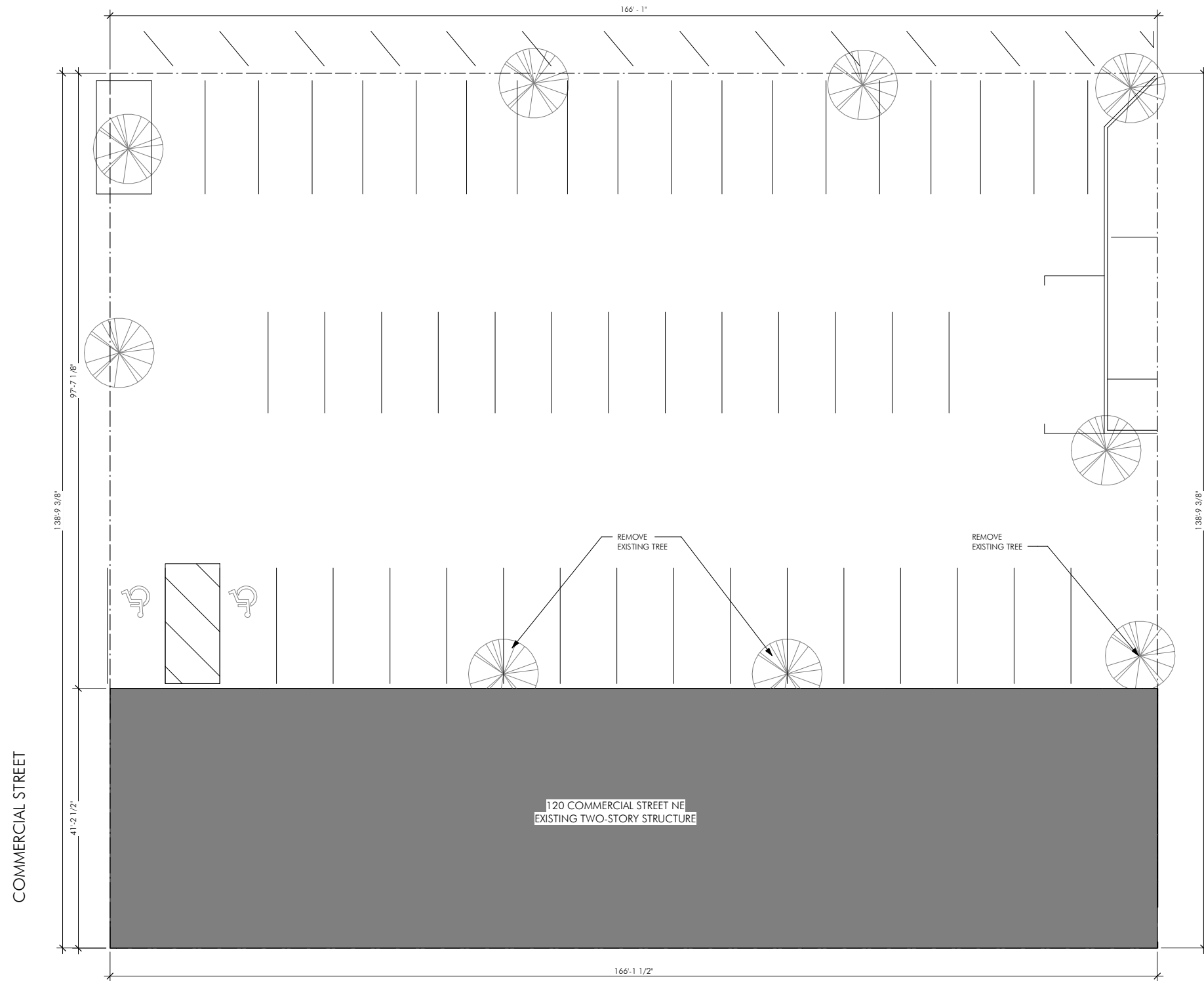

1 EXISTING SITE PLAN
0 5 10 20 30 1" = 10'-0"

SW 2833
Roycroft Vellum
Interior / Exterior

COLOR:
SW 2883 - ROYCROFT VELLUM

APPLICATION:
-WINDOW TRIM
-WALL TRIM



WALL TILE:
DAL TILE - HLO2 RAFFIA 6"X6"

APPLICATION:
-BELOW GLAZING AT WEST FACE
-BELOW ROLLUP DOORS AT NORTH FACE



OPENINGS:
ANODIZED ALUMINIUM
TO MATCH EXISTING
WINDOW FRAMES

APPLICATION:
-NEW WINDOWS,
STOREFRONT AND
OVERHEAD DOORS

SW 2813
Downing Straw
Interior / Exterior

COLOR:
SW 2813 - DOWNING STRAW

APPLICATION:
-UPPER WALL
-ABOVE GLAZING AT LOWER
LEVEL



EXISTING BRICK TO REMAIN



ROOFING:
PROFILED METAL ROOF

APPLICATION:
-NEW AWNING ALONG
COMMERCIAL STREET
-ROOF OF NEW WOOD
CANOPY

SW 2824
Renwick Golden Oak
Interior / Exterior

COLOR:
SW 2824 - RENWICK GOLDEN
OAK

APPLICATION:
-LOWER WALL



SOFFITS:
CEDAR PLANKS-6 " EXPOSURE
W/ NATURAL FINISH

APPLICATION:
-UNDERSIDE OF ENTRY SOFFIT
-FINISH BELOW NEW WOOD
CANOPY



CONCRETE PLANTER:
POLISHED FINISH

APPLICATION:
-PLANTERS ADJACENT
TO BUILDING AT NEW
WOOD CANOPY

SW 2803
Rookwood Terra Cotta
Interior / Exterior

COLOR:
SW 2803 - ROOKWOOD TERRA
COTTA

APPLICATION:
-AT NORTH SIDE ENTRANCE
ACCENT WALL



The Venice

ALWAYS FREE SHIPPING AND NO RESTOCKING FEES!



Galvanized

* Choose A Color



Galvanized

The Venice

★★★★★ 3 Review(s)

Your Price: \$139.00

~~Retail Price: \$199.00~~

You Save: \$60.00 (30%)

[view instructions](#)

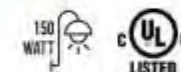

Availability: In Stock.

Free Shipping.

Part Number: A9-S123-8

Customization:

Manufacturing sign lights locally has the added benefit of being able to customize both color and gooseneck bends

Steel Construction :

Spun using 18 gauge American steel to create a strong fixture that is able to withstand harsh weather conditions.

Porcelain #30 Medium Base Socket:

Assembled with (6ft) of 18 Gauge Solid Wire Leads (black, white & green) and a threaded die-cast base. The socket is held in place with a matching threaded covernut. The Covernut is tightened counter clockwise.

Weather Resistant Finishing:

Steel Lighting fixtures are all rated for Outdoor use and are finished to withstand heavy wind and rusting. If powder coated, the interior of the fixture is white while the exterior is your color of choice. If galvanized please note that the finish is by nature inconsistent from one product to the next.

Feature: Restaurant Sign Lights

Light Bulbs / LED Retrofit Modules / 4000K - 5-6 Inch - 13.5W - Dimmable LED Epiq Downlight Retrofit Module - Baffle Trim - E26 Medium Base - Wet Location - American Lighting

4000K - 5-6 INCH - 13.5W - DIMMABLE LED EPIQ DOWNLIGHT RETROFIT MODULE - BAFFLE TRIM - E26 MEDIUM BASE - WET LOCATION - AMERICAN LIGHTING



Item #:
E56-B40
American Lighting

Usually ships in 2-3 business days

\$4.99 Flat-Rate Or
FREE US Shipping On Orders \$100 and Above

THIS PRODUCT IS CURRENTLY OUT OF STOCK AND UNAVAILABLE.

Product Overview

SHOP LIGHTUP.COM

- Adjustable mounting brackets accommodate 5in or 6in housings
- Decorative baffle trim
- 4000K color temperature
- Energy Star compliant
- ETL listed for wet locations



Need Assistance?

- [Live Chat](#) M-F 9am-4pm ET
- [Email Us](#)

DESCRIPTION

SPECIFICATIONS

ACCESSORIES

0 REVIEWS

0 Q&A

Specifications

Brand	American Lighting	Color Rendering Index (CRI)	90	Color Temperature	Cool White
Condition	New	Diameter (in)	7.375	Diffuser / Lens	Frosted, Polycarbonate
Dimmable	Yes	Energy Star	Yes	ETL Listed	Yes
Height (in)	3.375	Input Voltage	120V	Kelvin Color Temperature	4000K
Length (in)	19.5	Light Bulb Base Type	E26 Medium Screw	Light Fixture Type	LED Retrofit Downlight
Light Source	LED	Location Rating	Wet	Locations	Indoor, Outdoor
Lumens	1000	Mounting Hardware Incl	Yes	Mounting Type	Recessed Housing
Number of LEDs	1	Power Method	Screw-In	Quantity Being Sold	1
Recessed Diameter	5in, 6in	Recessed Trim Type	Baffle	Recommended Dimmer	Electronic Low Voltage
Trim Secures to Housing	Torsion Springs	Voltage System	Line Voltage	Wattage	13.5
Finish	Dark Bronze, White				

Wall luminaires with cutoff optics

Housing: Constructed of copper free die-cast aluminum alloy. The housing uses stainless steel inserts for enclosure attachment. Mounts over a standard 3½" or 4" octagonal wiring box. Die castings are marine grade, copper free ($\leq 0.3\%$ copper content) A360.0 aluminum alloy.

Enclosure: Tempered, matte glass lens. One piece die-cast, copper free, louvered, aluminum face plate secured to the housing with four captive socket head, stainless steel screws. Semi specular, anodized aluminum internal reflector. Fully gasketed for water tight operation using a silicone rubber gasket.

Electrical: 29.8W LED luminaire, 34 total system watts, -40°C start temperature. Integral 120V through 277V electronic LED driver, 0-10V dimming. LED module(s) are available from factory for easy replacement. Standard LED color temperature is 3000K with an 85 CRI. Available in 4000K (85 CRI); add suffix K4 to order.

Note: LEDs supplied with luminaire. Due to the dynamic nature of LED technology, LED luminaire data on this sheet is subject to change at the discretion of BEGA-US. For the most current technical data, please refer to www.bega-us.com.

Finish: All BEGA standard finishes are polyester powder coat with minimum 3 mil thickness. Available in four standard BEGA colors: Black (BLK); White (WHT); Bronze (BRZ); Silver (SLV). To specify, add appropriate suffix to catalog number. Custom colors supplied on special order

CSA certified to U.S. and Canadian standards, suitable for wet locations. Protection class IP65

Weight: 7.5 lbs.

Luminaire Lumens: 3558

Type:
 BEGA Product:
 Project:
 Voltage:
 Color:
 Options:
 Modified:

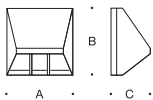

Lamp	A	B	C
22260 29.8W LED	11	11	5½

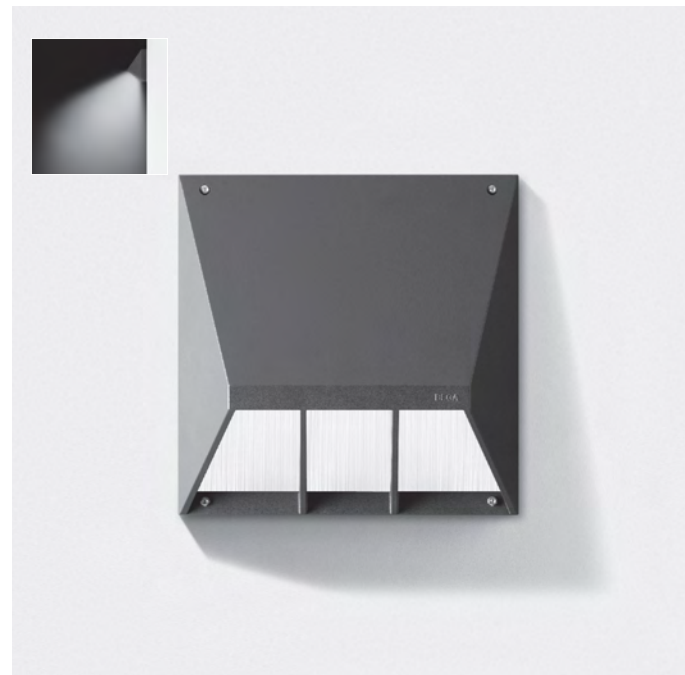



LED ceiling and wall luminaires

A new series of compact, powerful and efficient LED luminaires which are suitable for ceiling and wall applications. Two types of glass are available in different luminaire diameters. The three-ply opal glass as well as the thick-walled crystal glass with its impressive ice edges are hand-blown masterpieces. But only our reliable and cost effective LED technology makes luminaires with this shallow projection possible. BEGA can supply you with suitable LED replacement modules for up to 20 years after the purchase of LED luminaires – see page 415. Further LED technical data, e.g. luminous flux, CRI and dimming are provided on the individual luminaire specification sheets, available at www.bega-us.com.



Crystal glass, inside white



Three-ply opal glass

LED ceiling and wall luminaires
 Aluminum housing
 Crystal glass, white inside or three-ply opal glass with screw neck
 Integral electronic driver - dimmable 0-10 V
 Color temperature 3000 K (for 4000 K add suffix K4)
 Finish: Black (BLK) White (WHT)
 Silver (SLV) Bronze (BRZ)
 UL or CSA listed, suitable for wet locations (see page 417)
 Protection class IP 64

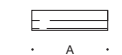

Crystal Glass · inside white

	Lamp	A	B
33682 ADA	17.4 W LED	10 ^{3/8}	2 ^{5/8}
33683 ADA	26.0 W LED	12	2 ^{5/8}

Opal Glass

	Lamp	A	B
33680 ADA	17.4 W LED	10 ^{3/8}	2 ^{5/8}
33681 ADA	26.0 W LED	12	2 ^{5/8}

60% PRELIMINARY SET
NOT FOR
CONSTRUCTION

IN THE EVENT CONFLICTS ARE DISCOVERED
BETWEEN THE ORIGINAL SIGNED AND SEALED
DOCUMENTS PREPARED BY THE ARCHITECTS
AND/OR THEIR CONSULTANTS, AND ANY COPY OF
THE DOCUMENTS TRANSMITTED BY MAIL, FAX,
ELECTRONICALLY OR OTHERWISE, THE ORIGINAL
SIGNED AND SEALED DOCUMENTS SHALL GOVERN.

PROJECT # 2018-012
DATE: 7/13/2018

REVISIONS

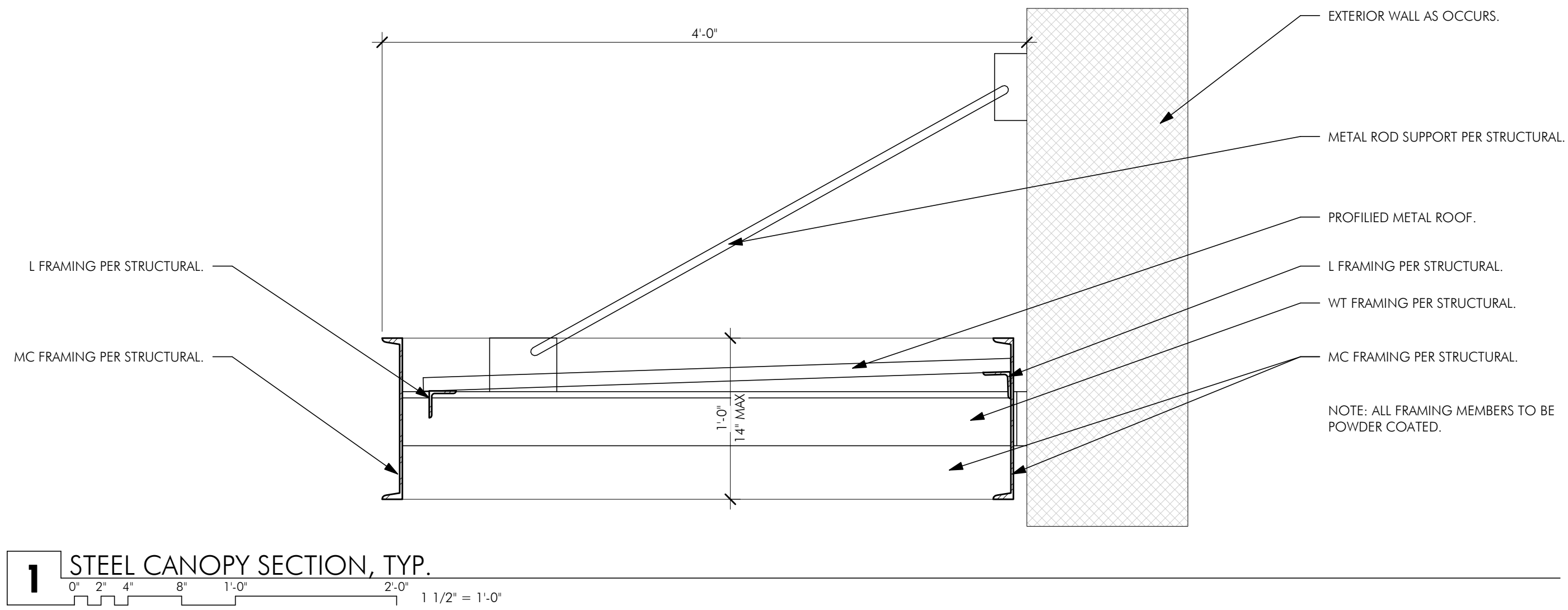

1 STEEL CANOPY SECTION, TYP.

0' 2' 4' 6' 1'-0" 2'-0" 1 1/2" = 1'-0"

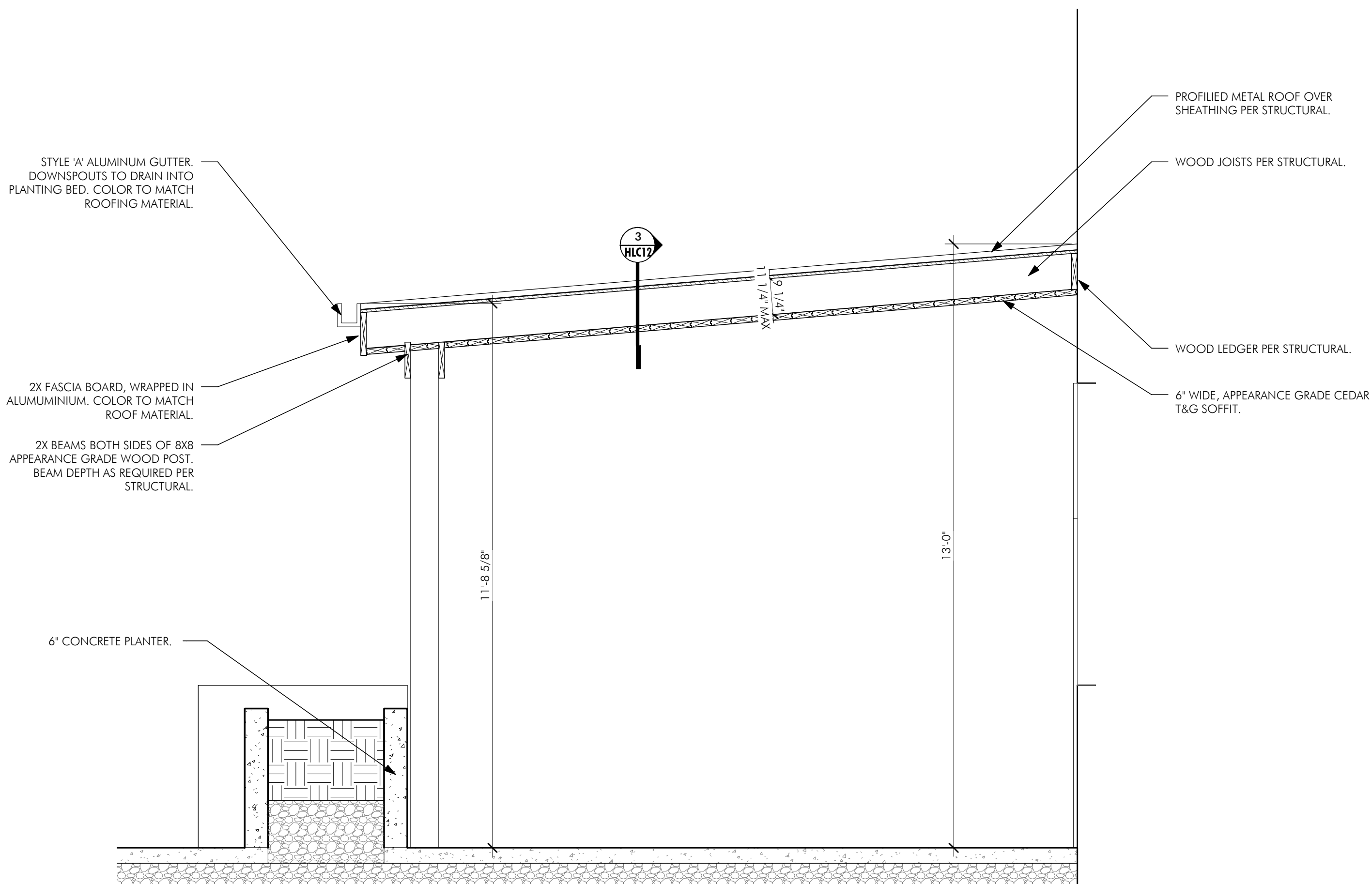

2 WOOD CANOPY SECTION

0' 1' 2' 4' 6' 1'-0" 1 1/2" = 1'-0"

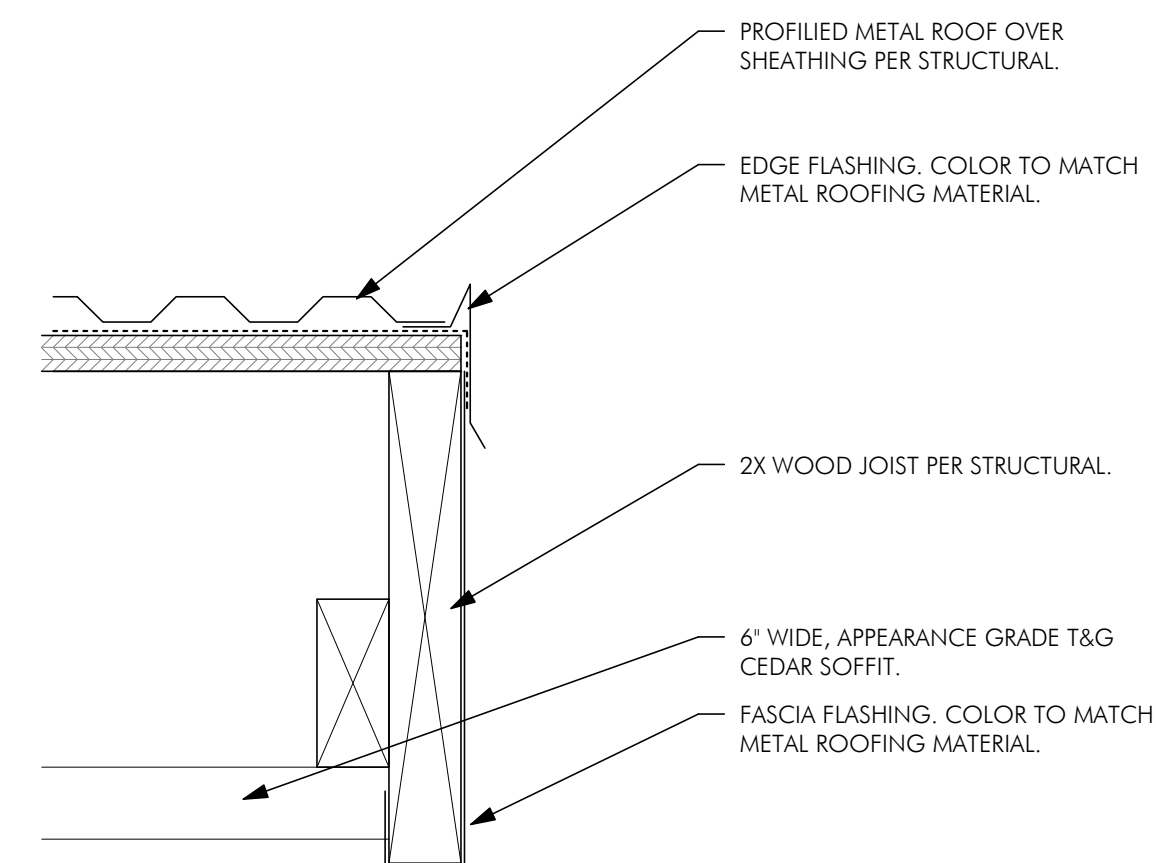

3 WOOD CANOPY EDGE CONDITION

0' 1' 2' 4' 6' 1'-0" 3" = 1'-0"

BUILDING IMPROVEMENTS FOR:
120 COMMERCIAL ST. NE
SALEM, OREGON 97301

SHEET:
HLC12

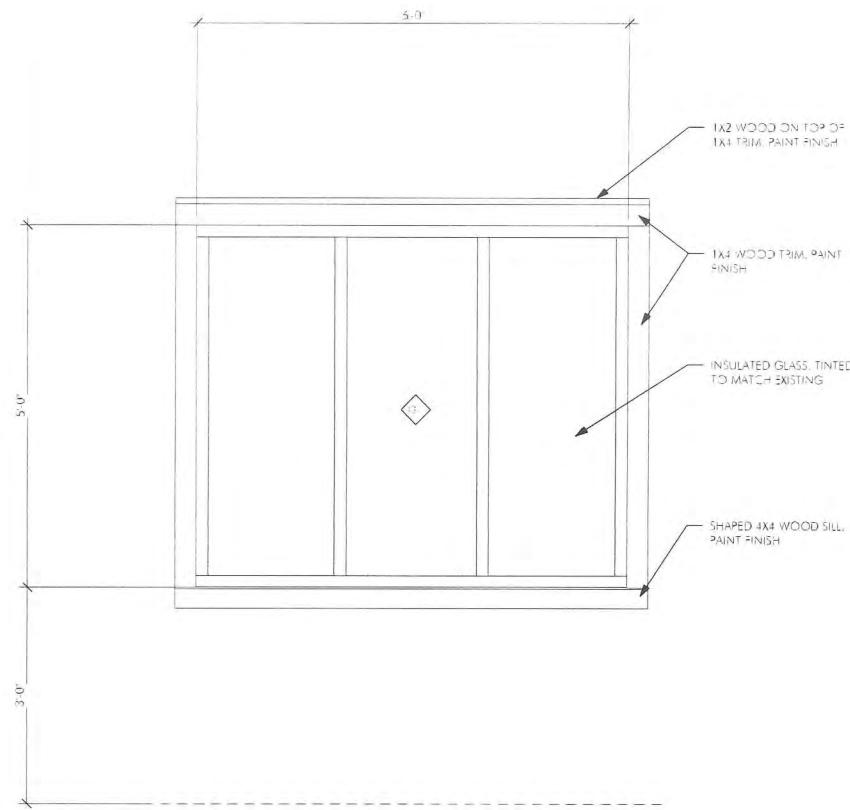

1 WINDOW, TYPICAL

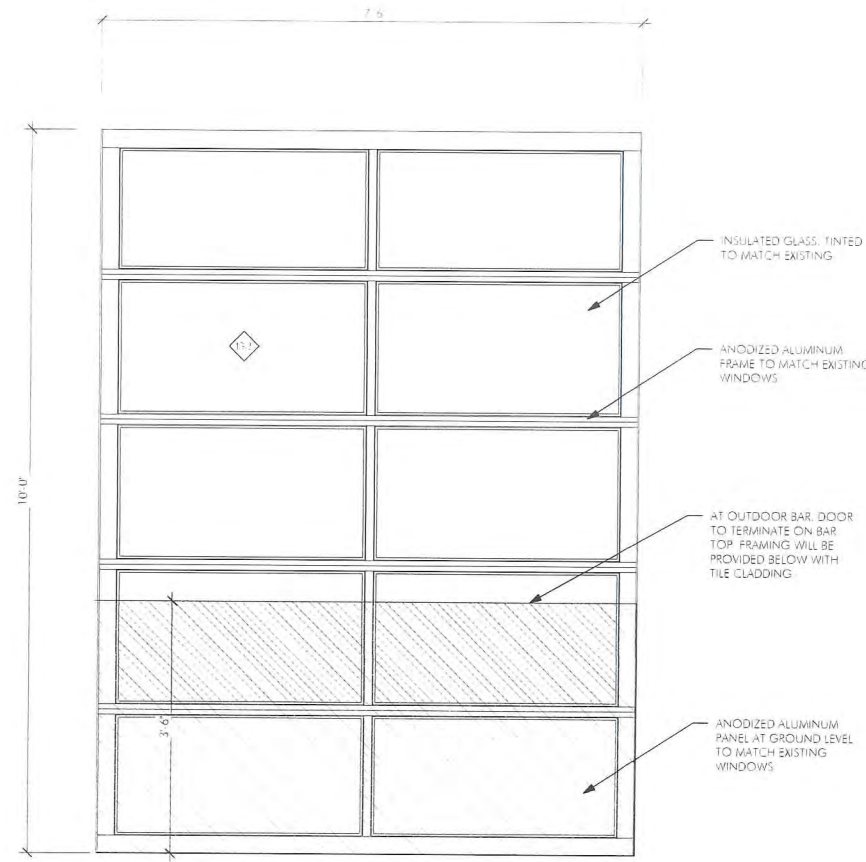

2 OVERHEAD DOOR, TYPICAL

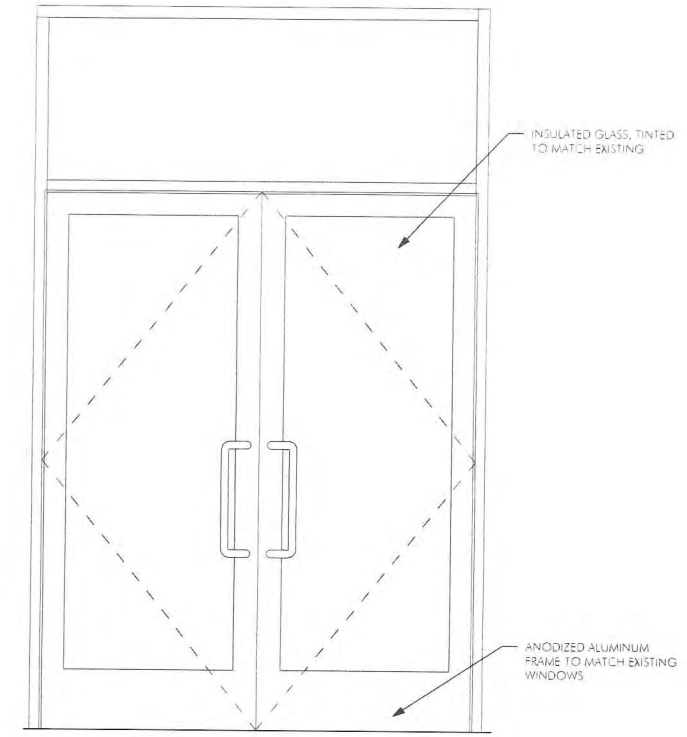

3 STOREFRONT, TYPICAL

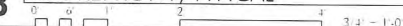

IT IS HEREBY CERTIFIED THAT THE ARCHITECT HAS REVIEWED THE PLANS AND SPECIFICATIONS AND IS NOT PROVIDING ANY GUARANTEE OR WARRANTY OF ANY KIND. THE ARCHITECT'S LIABILITY IS LIMITED TO THE PROFESSIONAL SERVICES PROVIDED BY HIMSELF OR HERSELF. THE ARCHITECT IS NOT RESPONSIBLE FOR ANY CONSTRUCTION DEFECTS OR OMISSIONS. THE ARCHITECT'S LIABILITY IS LIMITED TO THE PROFESSIONAL SERVICES PROVIDED BY HIMSELF OR HERSELF.

PROJECT # 2018-012
DATE: 7/5/2018

REVISIONS

BUILDING IMPROVEMENTS FOR:
120 COMMERCIAL ST. NE
SALEM, OREGON 97301

SHEET:

HLC 5