

NOTICE OF DECISION

PLANNING DIVISION
555 LIBERTY ST. SE, RM 305
SALEM, OREGON 97301
PHONE: 503-588-6173
FAX: 503-588-6005



*Si necesita ayuda para comprender esta informacion, por favor llame
503-588-6173*

DECISION OF THE HISTORIC PRESERVATION OFFICER

MINOR HISTORIC DESIGN REVIEW CASE NO.: HIS21-15

APPLICATION NO.: 21-111857-DR

NOTICE OF DECISION DATE: September 29, 2021

SUMMARY: A proposal to add a new bike share station and signage in Bush's Pasture Park.

REQUEST: Class 2 Minor Historic Design Review of a proposal to add a new bike share station and associated signage in the existing parking lot south of Mission Street SE, north of Willamette University athletic fields within Bush's Pasture Park, a historic contributing resource within the Gaiety Hill/Bush's Pasture Park National Register Historic District on property zoned PA (Public Amusement) and located at 600 Mission Street SE, (Marion County Assessors Map and Tax Lot number: 073W27D00100).

APPLICANT: Evan Osborne

LOCATION: 600 Mission St SE, Salem OR 97302

CRITERIA: Salem Revised Code (SRC) Chapters 230.036(b) – Signs

FINDINGS: The findings are in the attached Decision dated September 29, 2021.

DECISION: The **Historic Preservation Officer (a Planning Administrator designee)** **APPROVED** Minor Historic Design Review Case No. HIS21-15 based upon the application materials deemed complete on July 28, 2021 and the findings as presented in this report.

The rights granted by the attached decision must be exercised, or an extension granted, by October 15, 2023, or this approval shall be null and void.

Application Deemed Complete:	<u>July 28, 2021</u>
Notice of Decision Mailing Date:	<u>September 29, 2021</u>
Decision Effective Date:	<u>October 15, 2021</u>
State Mandate Date:	<u>November 25, 2021</u>

Case Manager: Kimberli Fitzgerald, kfitzgerald@cityofsalem.net, 503-54-02397

This decision is final unless written appeal and associated fee (if applicable) from an aggrieved party is filed with the City of Salem Planning Division, Room 320, 555 Liberty Street SE, Salem OR 97301, or by email at planning@cityofsalem.net, no later than 5:00 p.m. Thursday, October 14, 2021. The notice of appeal must contain the information required by SRC 300.1020 and must state where the decision failed to conform to the provisions of the applicable code section, SRC Chapter(s) 230.

The appeal fee must be paid at the time of filing. If the appeal is untimely and/or lacks the proper fee, the appeal will be rejected. The Historic Landmarks Commission will review the appeal at a public hearing. After the hearing, the Historic Landmarks Commission may amend, rescind, or affirm the action, or refer the matter to staff for additional information.

The complete case file, including findings, conclusions and conditions of approval, if any, is available for review by contacting the case manager, or at the Planning Desk in the Permit Application Center, Room 305, City Hall, 555 Liberty Street SE, during regular business hours.

<http://www.cityofsalem.net/planning>

***Si necesita ayuda para comprender esta informacion, por favor llame
503-588-6173***

BEFORE THE PLANNING ADMINISTRATOR OF THE CITY OF SALEM

**HISTORIC DESIGN REVIEW CASE NO. HIS21-15
DECISION**

**IN THE MATTER OF APPROVAL OF) MINOR HISTORIC DESIGN REVIEW
HISTORIC DESIGN REVIEW)
CASE NO. HIS21-15)
600 MISSION STREET SE) SEPTEMBER 29, 2021**

In the matter of the application for a Minor Historic Design Review submitted by Evan Osborne, the Historic Preservation Officer (a Planning Administrator Designee), having received and reviewed evidence and the application materials, makes the following findings and adopts the following order as set forth herein.

REQUEST

SUMMARY: A proposal to add a new bike share station and signage in Bush's Pasture Park.

REQUEST: Class 2 Minor Historic Design Review of a proposal to add a new bike share station and associated signage in the existing parking lot south of Mission Street SE, north of Willamette University athletic fields within Bush's Pasture Park, a historic contributing resource within the Gaiety Hill/Bush's Pasture Park National Register Historic District on property zoned PA (Public Amusement) and located at 600 Mission Street SE, (Marion County Assessors Map and Tax Lot number: 073W27D00100).

A vicinity map illustrating the location of the property is attached hereto, and made a part of this decision (**Attachment A**).

DECISION

APPROVED based upon the application materials deemed complete on July 28, 2021 and the findings as presented in this report.

FINDINGS

1. Minor Historic Design Review Applicability

SRC230.020(f) requires Historic Design Review approval for any alterations to historic resources as those terms and procedures are defined in SRC 230. The Planning Administrator shall render a decision supported by findings that explain conformance or lack thereof with relevant design standards, state the facts relied upon in rendering the decision, and explain justification for the decision.

PROPOSAL

The applicant is proposing to install a new bike share station and associated signage in the existing parking lot south of Mission Street SE, north of Willamette University athletic fields within Bush's Pasture Park (**Attachment B**). The bike station will be of metal and wood and will be comprised of ten metal bike stands approximately six feet wide affixed to a metal base

extending approximately twenty-two feet (267.35”). A free-standing wooden sign 12” by 48” in size will be affixed to the metal base utilizing steel footings. The proposed signage will be a beige and tan color, and the applicant has proposed to install rough gravel at the foundation of the station. Staff determined that the following standards from Salem Revised Code: **230.036(b)Permanent non-historic signs** are applicable to this project.

SUMMARY OF RECORD

The following items are submitted to the record and are available upon request: All materials submitted by the applicant, including any applicable professional studies such as traffic impact analysis, geologic assessments, and stormwater reports; any materials and comments from public agencies, City departments, neighborhood associations, and the public; and all documents referenced in this report.

APPLICANT’S STATEMENT

A request for historic design review must be supported by proof that it conforms to all applicable criteria imposed by the Salem Revised Code. The applicants submitted a written statement, which a portion of is included as **Attachment C** in this staff report.

Staff utilized the information from the applicant’s statements to evaluate the applicant’s proposal and to compose the facts and findings within the staff report. Salem Revised Code: **230.036(b)Permanent non-historic signs** are applicable to this project.

FACTS & FINDINGS

1. Historic Designation

Under Salem Revised Code (SRC) Chapter 230, no exterior portion of a local historic resource, contributing, non-contributing building or new construction in a historic district shall be erected, altered, restored, moved or demolished until historic design review approval has been granted on the basis of the project’s conformity with the applicable criteria in SRC 230. Conditions of approval, if any, shall be limited to project modifications required to meet the applicable criteria.

According to SRC 230.020(f), historic design review approval shall be granted if the application satisfies the applicable standards set forth in Chapter 230. For Class 1 and Class 2 Minor Historic Design Review decisions HLC staff, the Historic Preservation Officer (a designee of the Planning Administrator), shall render their decision supported by findings that explain conformance or lack thereof with relevant design standards, state the facts relied upon in rendering the decision, and explain justification for the decision.

2. Historic Significance

According to nomination documents the ninety-five acre Bush’s Pasture Park is a significant character defining feature within the Gaiety Hill/Bush’s Pasture Park Historic District. Nine acres of the original Bush’s Pasture Park were sold to Willamette University in 1946 and now contain McCulloch Stadium and ballfield as well as the associated parking lot abutting Mission Street which is an intrusion into the character of the park. However, its location set to the east

and south below the ridge line, reduces any impact this has on the overall integrity of the overall original pasture character of Bush's Pasture Park.

3. Neighborhood and Citizen Comments

The subject property is located within the South-Central Association of Neighbors Association (SCAN). A Request for Comments was sent to the neighborhood association, and surrounding property owners and tenants within 250 feet of the property pursuant to Salem Revised Code (SRC) requirements. Comments were received from Richard Pine, John (Andy) Porophy as well as from Sue Zeev and David Runseen who had no objection to the proposal. Comments were received from Eileen Williamson who expressed concerns about who will be responsible for returning any abandoned bikes (**Attachment D**). The Request for Comments was inadvertently sent to the Central Area Neighborhood Development Organization (CANDO) July 28, 2021. Comments were received from Michael Livingston, CANDO Vice-Chair (**Attachment D1**), with only support for the project expressed. A revised Request for Comments was sent to the SCAN neighborhood association on August 25, 2021 pursuant to Salem Revised Code (SRC) requirements, with an extended comment period through September 8, 2021. The following comments were received from Jon Christenson, Chair of the SCAN Historic Preservation, Parks & Gardens Committee. Below are the comments along with the applicant and staff's response (staff has paraphrased/summarized the comments, for the full SCAN comment narrative please see **Attachment D2**; for the applicant's full response please see **Attachment E**):

1. *The SCAN Board is on record in support of pedestrian and biking opportunities and this station could work well with the nearby AMTRAK bike share station.*

Response: Ride Salem appreciates the support of the neighborhood association and is working to offer access to the bike share system by locating stations strategically throughout the City of Salem.

2. *Gaiety Hill/Bush's Pasture Park is a National Register Historic District and SRC 230.036(b)Signs requires that signage should be non-obscuring and color can be a distraction or alternatively it can be a positive factor (eg. HIS16-30).*

Response: Ride Salem has been working with the City of Salem to ensure that the signage associated with the proposed station at Bush's Pasture Park is compatible and complimentary to the Park.

3. *Bike Share Sign Specifications: They request that the Location name on top of the Ride station have the correct accurate historic name of the Park: Bush's Pasture Park (not Bush Park)*

Response: Ride Salem is proposing to correct the proposed name to ensure it is accurate: the proposed name for this station is: Dr. Poly Chen Charitable Foundation station at Bush's Pasture Park.

4. *Recommend that the use of natural terrain colors be used instead of blue*

Response: Ride Salem is proposing to utilize a beige and tan color scheme for the signage to ensure better compatibility with the natural terrain in the Park.

5. *Recommend the use of rough gravel as opposed to pea gravel and restoration of the bark chip area to be landscaped.*

Response: The applicant is proposing to use rough gravel as opposed to pea gravel and will also restore the bark chip area as much as feasible within the existing budget.

6. *Request that the share station, signage and bicycles be well maintained (see also Eileen Williamson's concern regarding abandoned bikes).*

Staff Response: The maintenance of the proposed bike share station is governed by the agreement signed by the applicant, the City Manager, the Public Works Director and the City Attorney in 2020. Specifically, Section 1 (D) Requirements for Operating #7 Maintenance & #8 Safety of Bikeshare Amenities which states in part: "Maintenance of all Bikeshare Amenities will be performed by Ride Salem."

7. *Request a Condition of Approval to require the company to remove the bike share station and sign and restore the landscape if the commercial venture is not successful.*

Staff Response: Conditions of Approval can only be adopted as part of a land use decision to ensure that the proposal better meets the applicable criterion. There are no applicable criterion within SRC 230.036 where this condition would apply. The removal of the proposed bike share station is governed by the agreement signed by the applicant, the City Manager, the Public Works Director and the City Attorney in 2020. Specifically, Section 2: Breach and Termination which states in part: "Upon termination of this Agreement, Ride Salem shall abandon the use of City property, and shall remove the bikeshare station(s) and bikes."

4. City Department and Public Agency Comments

The Building and Safety Division indicates that they have no concerns. The Planning Division has reviewed the proposal and since the applicant has demonstrated that the interior parking landscaping standard has been met there are no concerns. The Fire Department stated that they have no concerns. The Public Works Department has no concerns.

5. Historic Design Review

SRC Chapter SRC **Criteria: 230.036(b)Permanent non-historic signs** are applicable to this project. Table 230-1 defines this activity as a Class 2 Minor Historic Design Review. Historic Landmarks Commission staff reviewed the project proposal and has the following findings for the applicable criterion.

FINDINGS:

Criteria: 230.036(b)Permanent non-historic signs

(1) Materials. *New signs shall be constructed of wood or metal.*

Finding: The applicant is proposing to install a new bikeshare with associated signage that will be of wood and metal. Staff finds that SRC 230.036(b)(1) has been met.

(2) Design.

(A) Permanent non-historic signs shall be located:

(i) Within an existing sign frame attached to the historic structure provided this frame does not obscure significant features;

Finding: The proposed bike share and associated signage will not be attached to a historic structure therefore this standard is not applicable to the evaluation of this proposal.

(ii) On the building, flush to the building facade or perpendicular to the building not obscuring any character defining features of the historic resource;

Finding: The proposed bike share and associated signage will not be attached to a historic structure, but instead will be freestanding, therefore this standard is not applicable to the evaluation of this proposal.

(iii) On the historic site within an existing sign monument, provided it does not obscure any character defining features of the historic resource or site; or.

Finding: The applicant's proposed new bikeshare and freestanding signage will be installed on the northern portion of Bush's Pasture Park, below the ridge to the east, just to the south of Willamette athletic fields within the existing non-historic parking lot. The signage will not be installed within an existing sign monument. However, at the proposed location within an existing landscape island within the parking lot to the south of Mission Street SE, the proposal will not adversely impact any character defining features of Bush's Pasture Park. Staff finds that SRC 230.036(b)(2)(A)(iii) has been met.

(iv) On the site within 50 feet of the main entrance of the building or tenant space the sign is identifying, not obscuring any character defining features of the historic resource or site.

Finding: The proposed new bikeshare and signage will be installed within the existing parking lot abutting Mission Street SE, a main point of entry for visitors to Bush's Pasture Park. The proposed signage and associated bikeshare stand will not obscure or adversely impact any character defining features of Bush's Pasture Park. Staff finds that SRC 230.036(b)(2)(A)(iv) has been met.

(B) Permanent non-historic signs shall be attached:

(i) Into mortar joints, not into masonry; and

Finding: The applicant's proposed new signage will be freestanding, therefore this standard is not applicable to the evaluation of this proposal.

(ii) Where significant features are not obscured.

Finding: The applicant's proposed new signage and associated metal bike stand will be installed within an existing landscape island currently devoid of any landscaping or character defining features. No significant features will be obscured or damaged by the installation of the proposed new bikeshare facility. Staff finds that SRC 230.036(b)(2)(B)(ii) has been met.

(C) Any permanent non-historic sign that incorporates lighting shall:

(i) Not be electronic or internally illuminated;

Finding: The proposed signage will not incorporate any electronic lighting or internal illumination therefore this standard is not applicable to the evaluation of this proposal.

(ii) Only include lighting that indirectly illuminates the sign. In no case shall such lighting exceed 25 watts (250 nits) or point directly or indirectly at adjacent or neighboring properties within the district;

Finding: The proposed signage will not incorporate any indirect lighting therefore this standard is not applicable to the evaluation of this proposal.

(iii) Not have exposed conduit.

Finding: The applicant's proposal will not have any conduit, therefore this standard is not applicable to the evaluation of this proposal.

DECISION

Based upon the application materials deemed complete on July 28, 2021 and the findings as presented in this report, the application for HIS21-15 is **APPROVED**.







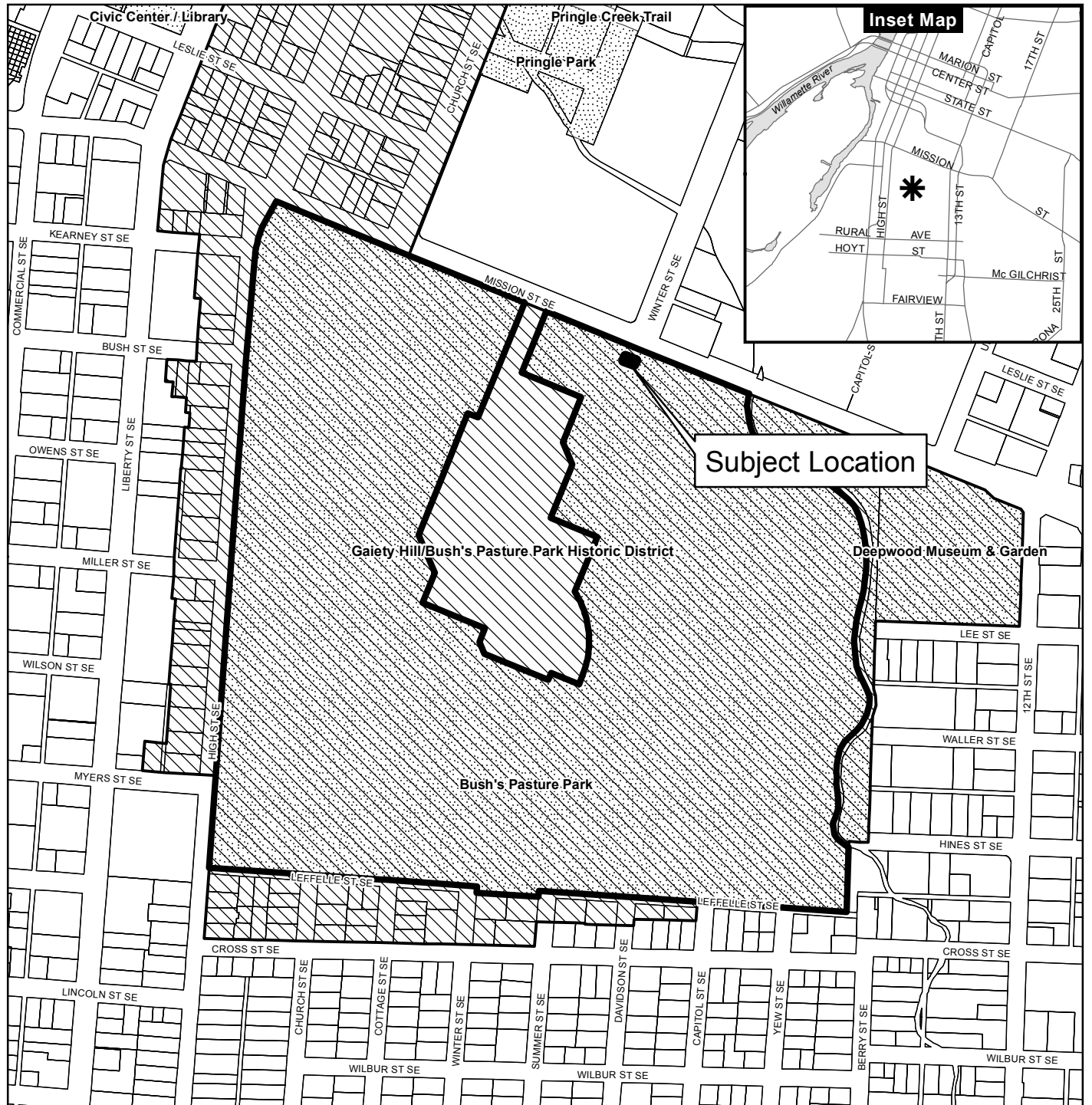

Kimberli Fitzgerald, AICP
Historic Preservation Officer
Planning Administrator Designee

Attachments: A. Vicinity Map
B. Site Plan
C. Portion of Applicant's Submittal Materials
D. Comment from Eileen Williamson
D1. Email of Support from CANDO
D2. Email from SCAN- Jon Christenson, Chair of the SCAN Historic Preservation, Parks & Gardens Committee
E. Ride Salem Response. 9-28-21

Vicinity Map 600 Mission Street SE



Legend

-  Taxlots
-  Urban Growth Boundary
-  City Limits
-  Outside Salem City Limits
-  Historic District
-  Schools
-  Parks



0 125 250 500 Feet





This product is provided as is, without warranty. In no event is the City of Salem liable for damages from the use of this product. This product is subject to license and copyright limitations and further distribution or resale is prohibited.

ATTACHMENT B

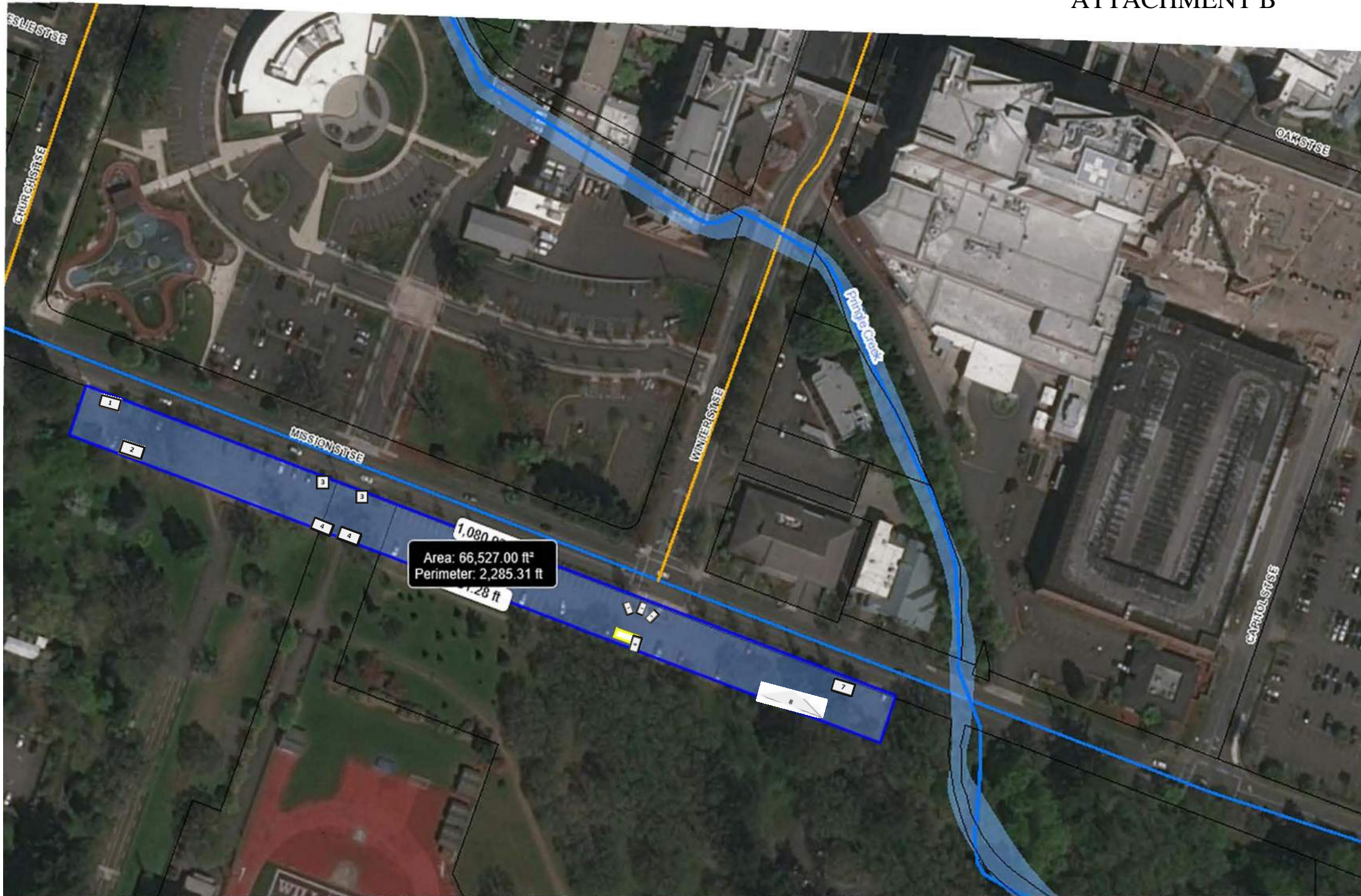
Bush Park/Ride Salem Station Land Use Planning 44.931196/-123.035968 (Lat/Long)

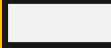

-  = Station Location
-  = Parking Lot Perimeter
-  = Lot Landscaping

Station Area (ft²) = 608.00
Parking Lot Area (ft²) = 66,527.00
Parking Area - Station Area = 65,919 ft²
Station-to-Parking Area ratio = 608/65,919 = **0.9%**
Lot Landscape total = (16.6'x24.4') + (52.3'x23.5') + (41.6'x20.1') + (18'x29.6') + (18'x29.6') + (25'x22.7') + (25'x22.7') + (4.5'x8') + (13'x15') + (13'x15') + (13'x15') + (48.8'x37.6') = **7,126.73 ft²**

Landscape-to-Usage Area ratio (ft²) = 7,126.73/66,527
= 10.7% Landscaped
= 89.3% Usage Area

Historic Alteration Review Worksheet

Site Address: _____

Resource Status: Contributing Non- Contributing Individual Landmark

Type of Work Activity Proposed: Major Minor

Chose One: Commercial District Individual Resource Public District
Residential District Sign

Replacement, Alteration, Restoration or Addition of:

Architectural Feature:

- Awning
- Door
- Exterior Trim, Lintel
- Other architectural feature _____
- Roof/Cornice
- Masonry/Siding
- Storefront
- Window(s) Number of windows: _____

Landscape Feature:

- Fence
- Streetscape
- Other Site feature (describe) _____

New:

- Addition
- Accessory Structure
- Sign
- Mural
- Accessibility Ramp
- Energy Improvements
- Mechanical Equipment
- Primary Structure

Will the proposed alteration be visible from any public right-of-way? Yes No

Project's Existing Material: _____ Project's New Material: _____

Project Description Additional details attached in following document titled 230.036(b) Permanent non-historic signs.

Briefly provide an overview of the type of work proposed. Describe how it meets the applicable design criteria in SRC Chapter 230. Please attach any additional information (i.e., product specification sheets) that will help staff and the HLC clearly understand the proposed work:

Additional details attached in following document titled 230.036(b) Permanent non-historic signs.

Signature of Applicant

Date Submitted/Signed

Bush Park Station Location

Rack Type- K2 Freestanding 10 parking

Location- 44.931199, -123.035977

Permit-

Notes- Concrete/Gravel pad to be installed

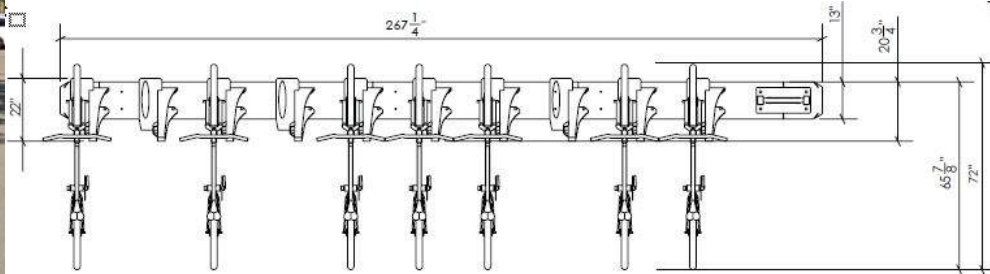

Ride Salem K1 Station- 10 bike

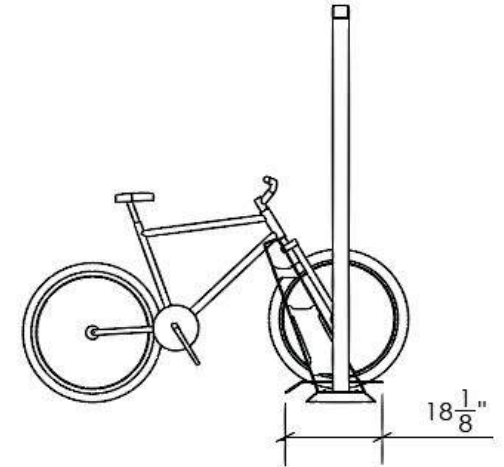
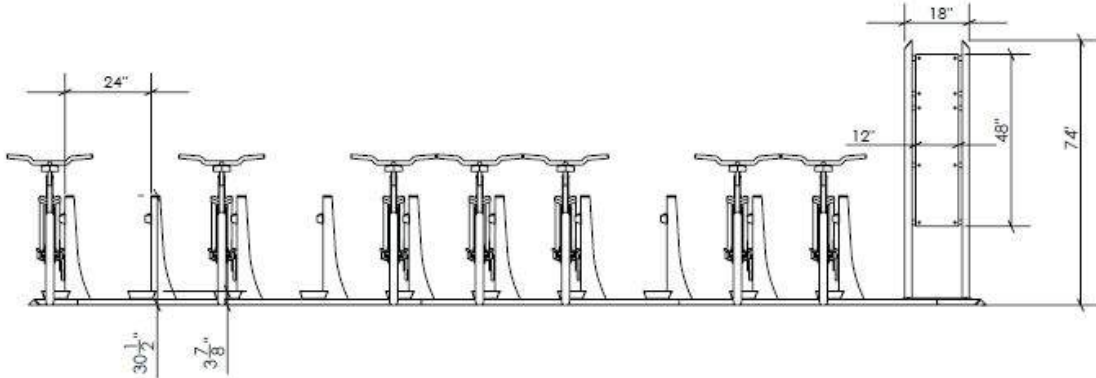
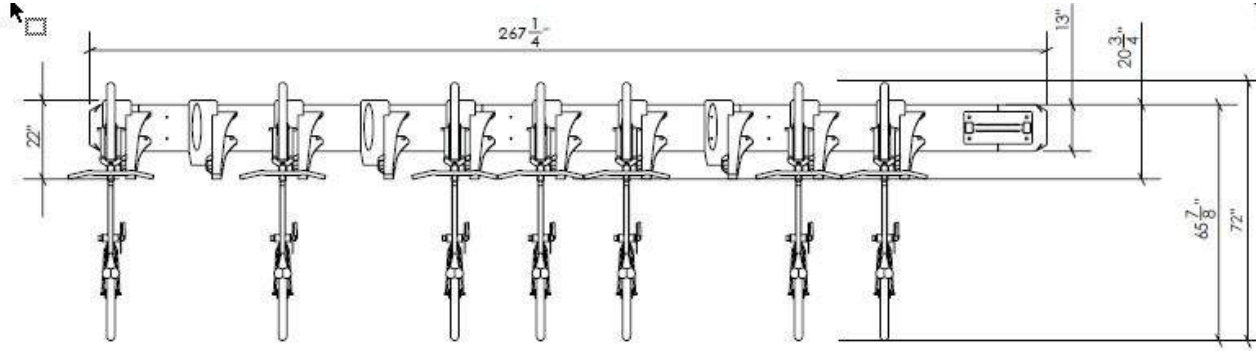

Bike Share Station Sign Spec Sheet

Overall sign dimensions:
12" wide x 48" tall.

Sponsor section dimensions:
12" wide x 5" tall.

Artwork (logo) requirements:
Native vector art (.ai, .eps or .pdf) preferred.
All type must be converted to outlines.
CMYK.

Raster artwork (.jpeg, .png) must be 300dpi
at 100% of final size or larger.

Other notes:
Station names must be 36 characters or
fewer.

System URLs must be 16 characters or
fewer, all lowercase.

All signs are 2 sided and identical on both
sides.

Station Sponsor Section

Color Scheme proposed for
Bush's Pasture Park Station
is BROWN & BEIGE
(not BLUE as pictured)



www.ridesalem.com/#how

REQUEST FOR COMMENTS*Si necesita ayuda para comprender esta informacion, por favor llame 503-588-6173*

REGARDING: Historic Design Review Case No. HIS21-15

RECEIVED

PROJECT ADDRESS: 600 Mission St SE, Salem OR 97302

AMANDA Application No.: 21-111857-DR

AUG 11 2021

COMMENT PERIOD ENDS: August 11, 2021

COMMUNITY DEVELOPMENT

SUMMARY: A proposal to add a new bike share station and signage in Bush's Pasture Park.**REQUEST:** Class 2 Minor Historic Design Review of a proposal to add a new bike share station and associated signage in the existing parking lot south of Mission Street SE, north of Willamette University athletic fields within Bush's Pasture Park, a historic contributing resource within the Gaiety Hill/Bush's Pasture Park National Register Historic District on property zoned PA (Public Amusement) and located at 600 Mission Street SE, (Marion County Assessors Map and Tax Lot number: 073W27D00100).

The Planning Division is interested in hearing from you about the attached proposal. Staff will prepare a Decision that includes consideration of comments received during this comment period. We are interested in receiving pertinent, factual information such as neighborhood association recommendations and comments of affected property owners or residents. The complete case file, including all materials submitted by the applicant and any applicable professional studies such as traffic impact analysis, geologic assessments, and stormwater reports, are available upon request.

Comments received by 5:00 p.m. Wednesday, August 11, 2021, will be considered in the decision process. Comments received after this date will be not considered. Comments submitted are public record. This includes any personal information provided in your comment such as name, email, physical address and phone number. Mailed comments can take up to 7 calendar days to arrive at our office. To ensure that your comments are received by the deadline, we recommend that you e-mail your comments to the Case Manager listed below.

CASE MANAGER: Kimberli Fitzgerald, Historic Preservation Officer, City of Salem, Planning Division; 555 Liberty St SE, Room 305, Salem, OR 97301; Phone: 503-540-2397; E-Mail: kfitzgerald@cityofsalem.net.

For information about Planning in Salem, please visit: <http://www.cityofsalem.net/planning>

PLEASE CHECK THE FOLLOWING THAT APPLY:

1. I have reviewed the proposal and have no objections to it.

2. I have reviewed the proposal and have the following comments: **WHO WILL BE RESPONSIBLE FOR RETURNING BIKES (ABANDONED)? DON'T WE NEED SAFE AND MULTIPLE BIKE PATHS BEFORE ENCOURAGING MORE BIKES? IN THE CITY'S CORE. THE RECENT EFFORT DOWNTOWN IS LAUDABLE BUT CONFUSING AND AWKWARD**

Name/Agency: EILEEN WILLIAMSON

Address: 1043 HIGH ST. SE

Phone: 503-881-9227

Email: 1942elw@gmail.com

Date: 7/30/21

IMPORTANT: IF YOU MAIL COMMENTS, PLEASE FOLD AND RETURN THIS POSTAGE-PAID FORM

Kimberli Fitzgerald

From: MICHAEL LIVINGSTON <michaellivingston1@comcast.net>
Sent: Monday, August 2, 2021 11:41 AM
To: Zachery Cardoso
Cc: Kimberli Fitzgerald
Subject: Re: Notice of Filing / Request for Comments - Case No HIS21-15 for 600 Mission St SE

ZACHERY,

On behalf of CANDO, I am submitting this comment in response to your request in Case No. HIS 21-15:

CANDO does not oppose the proposal to add a new bike share station and associated signage in the existing parking lot south of Mission St SE, north of Willamette University's athletic fields. The immediately adjacent area currently is set aside for parking, the new bike share station will have a negligible effect on the character of the historic district, and the proposal is consistent with CANDO's annual goal to "[s]upport initiatives that increase pedestrian and bicycle safety & access to downtown."

Michael Livingston
CANDO Vice Chair

On 07/28/2021 2:52 PM Zachery Cardoso <zcardoso@cityofsalem.net> wrote:

Hello,

The Notice of Filing / Request for Comments for Historic Design Review Case No. HIS21-15 for 600 Mission St SE is attached for your information. Comments are due **August 11, 2021 by 5:00 p.m.** Hard copies go out in the mail today for those of you who are to receive one.

Application Summary: A proposal to add a new bike share station and signage in Bush's Pasture Park.

Please direct questions or comments to the **CASE MANAGER:**

Kimberli Fitzgerald

Kimberli Fitzgerald

From: Howard Hall <friendsofhistoricsalem@gmail.com>
Sent: Monday, September 6, 2021 2:06 PM
To: Kimberli Fitzgerald
Subject: RFC - PROPOSED RIDE SALEM CYCLE SHARE STATION AND ASSOCIATED SIGNAGE IN GH/BPP NHD - Case No. HIS21-15

Kimberli Fitzgerald AICP
Historic Preservation Officer (HPO)
City of Salem
Civic Center, Room 305
555 Liberty Street S.E.
Salem, Oregon 97301

RE: CASE NO. HIS21-15 CLASS 2 HISTORIC DESIGN REVIEW - PROPOSED RIDE SALEM CYCLE SHARE STATION AT BUSH'S PASTURE PARK

Dear Officer Fitzgerald:

Thank you for the opportunity to comment. We would like to offer the following comments and considerations to you, the applicant and the City.

(1) The SCAN Board is on record in support of pedestrian and biking opportunities. SCAN is a walking residential neighborhood. The station could work well with the nearby AMTRAK bike share station.

(2) Gaiety Hill/Bush's Pasture Park is a National Historic District recognized by the U. S. National Park Service, U.S. Secretary of Interior, and the Keeper of the National Register of Historic Places. The 104 year old park is a central feature of SCAN Neighborhood, "at the heart of the

district" (NRHP), "one of the strongest..landscape features...a monument to Salem's early history..a major open space."

Signage should be compatible with the SRC period of significance, 1878-1938, and the goals of the City of Salem BPP/DEG Cultural Landscape Management Plan (CLMP) for the park space, "to deliver an enriching park experience..centered on the cultural landscape...Manage with a 'less is more' approach to keep the park experience clean, clear and uncluttered."

SRC 230.036 (b) Signs suggests that signage should be integrative to the setting and non-obscuring. Color can be a distraction. Color can also be a positive, integrating factor, supporting the landscape, in particular, a park, e.g., Case No. HIS16-30, see Attachment D, Interpretative Kiosks.

(3) Bike Share Station Sign Specifications. We request please from the applicant and the City HPO that the location name atop the Ride Station signage have the correct, accurate historical (NRHP Item Z, page 6) and formal (CLMP) name of the park (also SRC 230.200 (a)): BUSH'S PASTURE PARK (17-19 characters [under the prescribed limit of 36] -- not Bush Park.

(4) We recommend the use of natural terrain colors (greens, beige, browns). At this specific location - green - instead of blue used downtown at Ferry & Church or at the roadside NW Rehabilitation Associates.

We recommend "Statue of Liberty Green," "verde green" or what is commonly called "ODOT green." It was first used in the period of significance (1878-1938), by famed designer B. Conde McCullough. The technical name is federal standard 595 color 24272.

Mr. McCullough and his family lived two blocks from Bush's Pasture Park in the NHD.

(5) Project: New Material. Pea gravel has a tendency to migrate due to its shape. Rough gravel that is not round might be a better choice, as various shapes tend to lock together and not migrate. Pea gravel can create a fall hazard on pavement.

Consideration might be given to restoration of the bark chip area to its prior condition so it could be landscaped. An attractive landscaped setting is an enhancement and a visual draw.

(6) We ask that the share station, signage and bicycles be well maintained. The proposed bike share station is within Management Area 5 (92-96) of the BPP/DEG Cultural Management Plan (CLMP), a major entrance to the park, in primarily a residential neighborhood.

The proposed bike station is on City property, the signature historic park in the heart of Salem, and should be removed at any time if deemed to be in poor or hazardous condition by Public Works or Parks Operations.

(7) We request a Condition of Approval to require the company to remove the bike share station and sign and restore the landscape if the commercial venture is not successful. Some of the bike racks could be left for public use.

We welcome Ride Salem. We welcome thoughtful enhancements to the pedestrian and biking network in the SCAN Neighborhood.

Sincerely yours,

Jon Christenson MURP

Chair

SCAN Historic Preservation, Parks & Gardens Committee

Thank you, City of Salem and Neighborhood Associations, for providing Ride Salem the opportunity to collaborate with and contribute to our beloved city.

In response to comments and requests made by contributing Neighborhood Associations in Ride Salem's application offering bike-sharing station access via the Northeast edge of Bush's Pasture Park, please review our following responses to the numbered Neighborhood and Citizen Comments section found on page three of the City of Salem's Historic Design Review Case No. HIS21-15 respectively:

- 1) Ride Salem, a local 501(c)3 nonprofit, appreciates the advocacy expressed by the responding Neighborhood Associations. Our program strives to offer access to the bike-share system through a future station location within Bush's Pasture Park where the access point will compliment the Get There station located at AMTRAK's train depot, but also compliment a station located on the Southwest corner of the Willamette University campus on Ferry and Pringle Parkway Southeast, as well as locations at the Cherriots Downtown Transit Center, Riverfront Park, Wallace Marine Park and other virtual stations strategically placed within the downtown area of Salem.
- 2) Ride Salem has been working with the City of Salem, Public Works, Parks & Recreation, City Planning and the Historic Society to deliver a sign and station design complimentary to the surrounding beauty the Bush's Pasture Park provides.
- 3) During the application process, Ride Salem has been fortunate to acquire a generous sponsor willing to financially support the change requests made requiring additional costs. Because of this philanthropic contribution, Ride Salem has aligned with the request of changing of the station's name and location title with the following: Dr. Poly Chen Charitable Foundation station at Bush's Pasture Park.
- 4) In efforts to align with complimenting the natural terrain, a beige and tan color scheme has been chosen as opposed to the traditional blue formatting seen at other stations throughout the system. Please see attached exhibit reflecting this color and design.
- 5) Because of the additional charitable funding, Ride Salem is able to align with a request made for the more expensive rough gravel foundation in exchange for our originally planned pea gravel foundation. If budgeting allows, additional landscaping to refresh the old bark dust abutting the station site will be considered.
- 6) Ride Salem is actively collaborating with local organizations advocating for the continued success of Ride Salem's services. Conversations are being held entertaining the opportunity for a local bike shop to offer remote mechanic services on a routine basis. These efforts will be complimentary of the already offered services by volunteer staff throughout the operating year.
- 7) Ride Salem continues to collaborate with bike promotion and transportation service companies who may be a good fit in carrying on the legacy of Ride Salem's efforts. Until that day comes, Ride Salem will strive to be a continued benefit to the community. As our agreement with The City mandates, Ride Salem will abide by actions contractually required if our nonprofit governance and volunteers are unable to sustain the micromobility program.

In closing, thank you again for the community's engagement in this application process and we look forward to offering an active transportation access site and an opportunity to improve the quality of life within Bush's Pasture Park and surrounding neighborhoods.

On behalf of Ride Salem,

Respectfully,

Evan Osborne, MPH, PMP, BSRT(T) (ARRT)
President/CEO
Ride Salem

Dr. Poly Chen Charitable Foundation Station

Dr. Poly Chen
Charitable Foundation



... READY TO RIDE? ...

Download the **free koloni** app
or visit **ridesalem.com**

- > Create an account
- > View other station locations
- > Read the FAQs
- > **Start riding now!**



... HOW IT WORKS ...



1

JOIN

Download the **koloni** app and join the System Name bike share.



2

UNLOCK

Unlock a bike using your phone. For detailed instructions, click "How To" in the app.



3

RIDE

Enjoy your ride! Make quick stops along the way by locking your bike to any public bike rack.



4

RETURN & LOCK

When you're done riding, lock your bike to a  station and end your ride in the app.



10mph park speed limits
Please wear a helmet!
Self-service sanitation

Avoid Sidewalks
18+ Riders must be 18 or older.



Need Help? Call us at **503-576-1459** or visit www.RideSalem.com/#how to read our FAQs.

... GRAB A BIKE AND GO! ...



Want to learn more? Visit:

www.RideSalem.com