

# NOTICE OF DECISION

PLANNING DIVISION  
555 LIBERTY ST. SE, RM 305  
SALEM, OREGON 97301  
PHONE: 503-588-6173  
FAX: 503-588-6005



*Si necesita ayuda para comprender esta informacion, por favor llame  
503-588-6173*

## DECISION OF THE HISTORIC LANDMARKS COMMISSION

**HISTORIC DESIGN REVIEW CASE NO.:** HIS20-01

**APPLICATION NO.:** 19-126135-DR

**NOTICE OF DECISION DATE:** FEBRUARY 21, 2020

**SUMMARY:** A proposal to replace existing aluminum storefront doors and side lights on the primary facade of the Pearce Building (1940).

**REQUEST:** A Major Historic Design Review of a proposal to replace the existing aluminum storefront doors and side lights with a new storefront on the primary facade of the Pearce Building (1940), a historic contributing resource within Salem's Downtown National Register Historic District, located at 305-325 Court St. NE, 97301 (Marion County Assessor Map and Tax Lot number: 073W22DC 08000).

**APPLICANT:** Gene Bolante, Studio3 Architecture on behalf of The Pearce Building, LLC (William Venti, Kari Venti, Dino Venti, Leslie Venti)

**LOCATION:** 305-325 Court St NE

**CRITERIA:** Salem Revised Code (SRC) Chapters 230.040(d) - Storefronts

**FINDINGS:** The findings are in the attached Decision dated February 21, 2020.

**DECISION:** The **HISTORIC LANDMARKS COMMISSION APPROVED** Historic Design Review Case No. HIS20-01 based upon the application materials deemed complete on January 30, 2020 and the findings as presented in this report.

### VOTE:

Yes 7      No 0      Absent 2 (SCHWARTZ, CURTEMAN)

\_\_\_\_\_  
Jamie French, Chair  
Salem Historic Landmarks Commission

*This Decision becomes effective on March 17, 2020. No work associated with this Decision shall start prior to this date unless expressly authorized by a separate permit, land use decision, or provision of the Salem Revised Code (SRC).*

The rights granted by the attached decision must be exercised, or an extension granted, by March 17, 2022 or this approval shall be null and void.

Application Deemed Complete:	<u>January 30, 2020</u>
Public Hearing Date:	<u>February 20, 2020</u>
Notice of Decision Mailing Date:	<u>February 21, 2020</u>
Decision Effective Date:	<u>March 17, 2020</u>
State Mandate Date:	<u>May 29, 2020</u>

Case Manager: Kimberli Fitzgerald, [kfitzgerald@cityofsalem.net](mailto:kfitzgerald@cityofsalem.net), 503-540-2397

This decision is final unless written appeal from an aggrieved party is filed with the City of Salem Planning Division, Room 320, 555 Liberty Street SE, Salem OR 97301, no later than 5:00 p.m., Monday, March 16, 2020. Any person who presented evidence or testimony at the hearing may appeal the decision. The notice of appeal must contain the information required by SRC 300.1020 and must state where the decision failed to conform to the provisions of the applicable code section, SRC Chapter(s) 230. The appeal must be filed in duplicate with the City of Salem Planning Division. The appeal fee must be paid at the time of filing. If the appeal is untimely and/or lacks the proper fee, the appeal will be rejected. The Hearings Officer will review the appeal at a public hearing. After the hearing, the Hearings Officer may amend, rescind, or affirm the action, or refer the matter to staff for additional information.

The complete case file, including findings, conclusions and conditions of approval, if any, is available for review at the Planning Division office, Room 320, City Hall, 555 Liberty Street SE, during regular business hours.

<http://www.cityofsalem.net/planning>

***Si necesita ayuda para comprender esta informacion, por favor llame 503-588-6173***

## **DECISION OF THE SALEM HISTORIC LANDMARKS COMMISSION**

**CASE NO.** Historic Review Case No. HIS20-01

**FINDINGS:** Based upon the application materials, the facts and findings in the Staff Report incorporated herein by reference, and testimony provided at the Public Hearing of February 20, 2020, the Historic Landmarks Commission (HLC) finds that the applicant adequately demonstrated that their proposal complies with the applicable provisions of the Salem Revised Code (SRC) 230.050 as follows:

### **FINDINGS**

#### **230.040 Standards for Historic Contributing Buildings in Commercial Historic Districts (d) Storefronts**

### **FINDINGS**

#### ***(1) Materials.***

***(A) Original material shall, if possible, be retained or repaired.***

**Finding:** The HLC finds that the doors, sidelights and transom proposed for replacement are in poor condition and require replacement. In particular, the vent glass transom is leaking air and cannot be repaired. Therefore, it is not possible to retain and repair the door, sidelights and vent transom window. However, the majority of the original storefront material will be retained, including the character defining aluminum and glass display windows and stucco bulkheads. The HLC finds that Standard 230.040 (d)(1)(A) has been met.

***(B) Replacement materials shall be, to the greatest extent practicable, of the same type, quality, design, size, finish, proportions, and configuration of the original materials in the storefront.***

**Finding:** The HLC finds that the applicant is proposing to install new storefront doors, sidelights and a fixed transom window replicating the aluminum and glass material of the existing storefront of the Pearce Building. Therefore, the HLC finds that SRC 230.040 (d)(1)(B) has been met for this proposal.

#### ***(2) Design.***

***(A) To the extent practicable, original storefront components such as windows, door configuration, transoms, signage, and decorative features shall be preserved.***

**Finding:** The HLC finds that the applicant is proposing to preserve character defining features of the original storefront. The recessed door openings, sidelight and transom openings will be retained at the western and southern ends of this façade. The applicant is proposing to replace the original vent glass transom with a fixed glass transom window, due to the potential for water and air intrusion. The opening will remain the same, and this alteration is compatible with the exterior of the Pearce Building, therefore, the HLC finds that SRC 230.040(d)(2)(A) has been met.

**(B)** *Where the original storefront is too deteriorated to save, the commercial character of the building shall be retained through:*

*(i) A restoration of the storefront based on historical research and physical evidence.*

**Finding:** The HLC finds that the applicant is proposing to replicate and restore the doors and sidelights within the western and southern storefronts of the Pearce Building to their 1940 appearance, therefore SRC 230.040(d)(2)(B)(i) has been met for this portion of the proposal.

*(ii) Contemporary design that is compatible with the scale, design, materials, color and texture of historic compatible buildings in the district.*

**Finding:** The HLC finds that the applicant is proposing to modify the vent glass transom windows above the entry doors on the western and southern storefronts of the Pearce Building (1940), altering the design to a fixed glass transom window on each façade. These new transom windows will be installed within the existing openings above the entry doors on the western and southern facades of the Pearce Building. Overall, the HLC finds that the proposed alterations are compatible with the scale, design, and materials of the Pearce Building, therefore SRC 230.040(d)(2)(B)(ii) has been met for this proposal.

**(C)** *For buildings that provide a separate upper-story entrance on the exterior facade, the street-level entrance should be the primary focus of the building facade.*

**Finding:** There is no upper story entrance within the scope of this proposal, therefore the HLC finds that SRC 230.040(d)(2)(C) does not apply to the evaluation of this proposal.

**(D)** *Original openings that have been covered or blocked should be re-opened when feasible.*

**Finding:** There are no original openings that have been covered or blocked on the primary façade of the Pearce Building, therefore the HLC finds that SRC 230.040(d)(2)(C) does not apply to the evaluation of this proposal.

The Historic Landmarks Commission **APPROVES** the proposal.

**VOTE: Yes 7    No 0    Absent 2 (Schwartz, Curteman)    Abstain 0**

Attachments: A. Hearing Notice and Vicinity Map  
B. Excerpt from National Register Historic Resource Document  
C. Applicant's Submittal Materials

Prepared by Kimberli Fitzgerald, Historic Preservation Officer



# HEARING NOTICE

## LAND USE REQUEST AFFECTING THIS AREA

*There is a development proposal for the property listed in this notice and shown on the attached map. The City is seeking input from neighbors on the proposal. If you have questions or comments about the proposal, contact the case manager.*

*Esta carta es un aviso sobre una propuesta de desarrollo para la propiedad enumerada y que se muestra en el mapa adjunto. La ciudad está buscando la opinión de los vecinos sobre la propuesta. Si tiene preguntas o comentarios sobre la propuesta, póngase en contacto con nosotros al 503-588-6213*

<b>CASE NUMBER:</b>	Historic Design Review Case No. HIS20-01
<b>HEARING INFORMATION:</b>	<u>Historic Landmarks Commission, Thursday, February 20, 2020, 5:30 P.M., Council Chambers, Room 240, Civic Center, 555 Liberty Street SE, Salem, OR 97301</u>
<b>PROPERTY LOCATION:</b>	305-325 Court St NE, Salem OR 97301
<b>SUMMARY:</b>	A proposal to replace existing aluminum storefront doors and side lights on the primary facade of the Pearce Building (1940).
<b>CASE MANAGER:</b>	<b>Kimberli Fitzgerald, Historic Preservation Officer</b> , City of Salem Planning Division, 555 Liberty Street SE, Room 305, Salem, OR 97301. Telephone: 503-540-2397; E-mail: <a href="mailto:kfitzgerald@cityofsalem.net">kfitzgerald@cityofsalem.net</a> .
<b>NEIGHBORHOOD ORGANIZATION:</b>	<i>Neighborhood associations are volunteer organizations of neighbors coming together to make neighborhoods the best they can be. They receive notice of land use applications within their boundaries, and they often submit comments on the applications to the City. Neighborhood association meetings are open to everyone. Contact your neighborhood association to get involved:</i>  Central Area Neighborhood Development Organization (CAN-DO), Bruce Hoffman, Land Use Chair; Phone: (503) 781-8542; Email: <a href="mailto:bruhof@gmail.com">bruhof@gmail.com</a> .
<b>STAFF REPORT:</b>	The Staff Report will be available seven (7) days prior to the hearing and will thereafter be posted on the Community Development website: <a href="https://www.cityofsalem.net/notice">https://www.cityofsalem.net/notice</a> .
<b>ACCESS:</b>	The Americans with Disabilities Act (ADA) accommodations will be provided on request.
<b>CRITERIA:</b>	Salem Revised Code (SRC) Chapter(s) 230.040(d) - Storefronts  Salem Revised Code (SRC) is available to view at this link: <a href="http://bit.ly/salemorcode">http://bit.ly/salemorcode</a> . Type in the chapter number(s) listed above to view the applicable criteria.

<b>OWNER(S):</b>	The Pearce Building, LLC (William Venti, Kari Venti, Dino Venti, Leslie Venti)
<b>APPLICANT / AGENT(S):</b>	Gene Bolante, Studio3 Architecture
<b>PROPOSAL REQUEST:</b>	A Major Historic Design Review of a proposal to replace the existing aluminum storefront doors and side lights with a new storefront on the primary facade of the Pearce Building (1940), a historic contributing resource within Salem's Downtown National Register Historic District, located at 305-325 Court St. NE, 97301 (Marion County Assessor Map and Tax Lot number: 073W22DC 08000).
<b>HOW TO PROVIDE TESTIMONY:</b>	Any person wishing to speak either for or against the proposed request may do so in person or by representative at the Public Hearing. Written comments may also be submitted at the Public Hearing. Include case number with the written comments. Prior to the Public Hearing, written comments may be filed with the Salem Planning Division, Community Development Department, 555 Liberty Street SE, Room 305, Salem, Oregon 97301. Only those participating at the hearing, in person or by submission of written testimony, have the right to appeal the decision.
<b>HEARING PROCEDURE:</b>	<p>The hearing will be conducted with the staff presentation first, followed by the applicant's case, neighborhood organization comments, testimony of persons in favor or opposition, and rebuttal by the applicant, if necessary. The applicant has the burden of proof to show that the approval criteria can be satisfied by the facts. Opponents may rebut the applicant's testimony by showing alternative facts or by showing that the evidence submitted does not satisfy the approval criteria. A hearing is not a venue to ask questions of staff, the applicant or the decision maker(s) on this case but rather an opportunity to provide testimony to the decision maker(s) on the merits of the land use case; questions about the application, the recommended conditions of approval, or the Planning Administrator's recommendation, should be directed to the Case Manager prior to the hearing.</p> <p>Any participant may request an opportunity to present additional evidence or testimony regarding the application. A ruling will then be made to either continue the Public Hearing to another date or leave the record open to receive additional written testimony. Failure to raise an issue in person or by letter prior to the close of the Public Hearing with sufficient specificity to provide the opportunity to respond to the issue, precludes appeal to the Land Use Board of Appeals (LUBA) on this issue. A similar failure to raise constitutional issues relating to proposed conditions of approval precludes an action for damages in circuit court.</p> <p>Following the close of the Public Hearing a decision will be issued and mailed to the applicant, property owner, affected neighborhood association, anyone who participated in the hearing, either in person or in writing, and anyone who requested to receive notice of the decision.</p>
<b>MORE INFORMATION:</b>	Documents and evidence submitted by the applicant are available for review and paper copies can be obtained at a reasonable cost. You can also find out more information about the status of the proposed application on the City's online Permit Application Center at <a href="https://permits.cityofsalem.net">https://permits.cityofsalem.net</a> . Just enter the permit number listed here: 19 126135
<b>NOTICE MAILING DATE:</b>	January 30, 2020

**PLEASE PROMPTLY FORWARD A COPY OF THIS NOTICE TO ANY OTHER OWNER, TENANT OR LESSEE.**

**For more information about Planning in Salem:**

**<http://www.cityofsalem.net/planning>**

*It is the City of Salem's policy to assure that no person shall be discriminated against on the grounds of race, religion, color, sex, marital status, familial status, national origin, age, mental or physical disability, sexual orientation, gender identity and source of income, as provided by Salem Revised Code Chapter 97. The City of Salem also fully complies with Title VI of the Civil Rights Act of 1964, and related statutes and regulations, in all programs and activities. Disability-related modification or accommodation, including auxiliary aids or services, in order to participate in this meeting or event, are available upon request. Sign language and interpreters for languages other than English are also available upon request. To request such an accommodation or interpretation, contact the Community*

*Development Department at 503-588-6173 at least three business days before this meeting or event.*





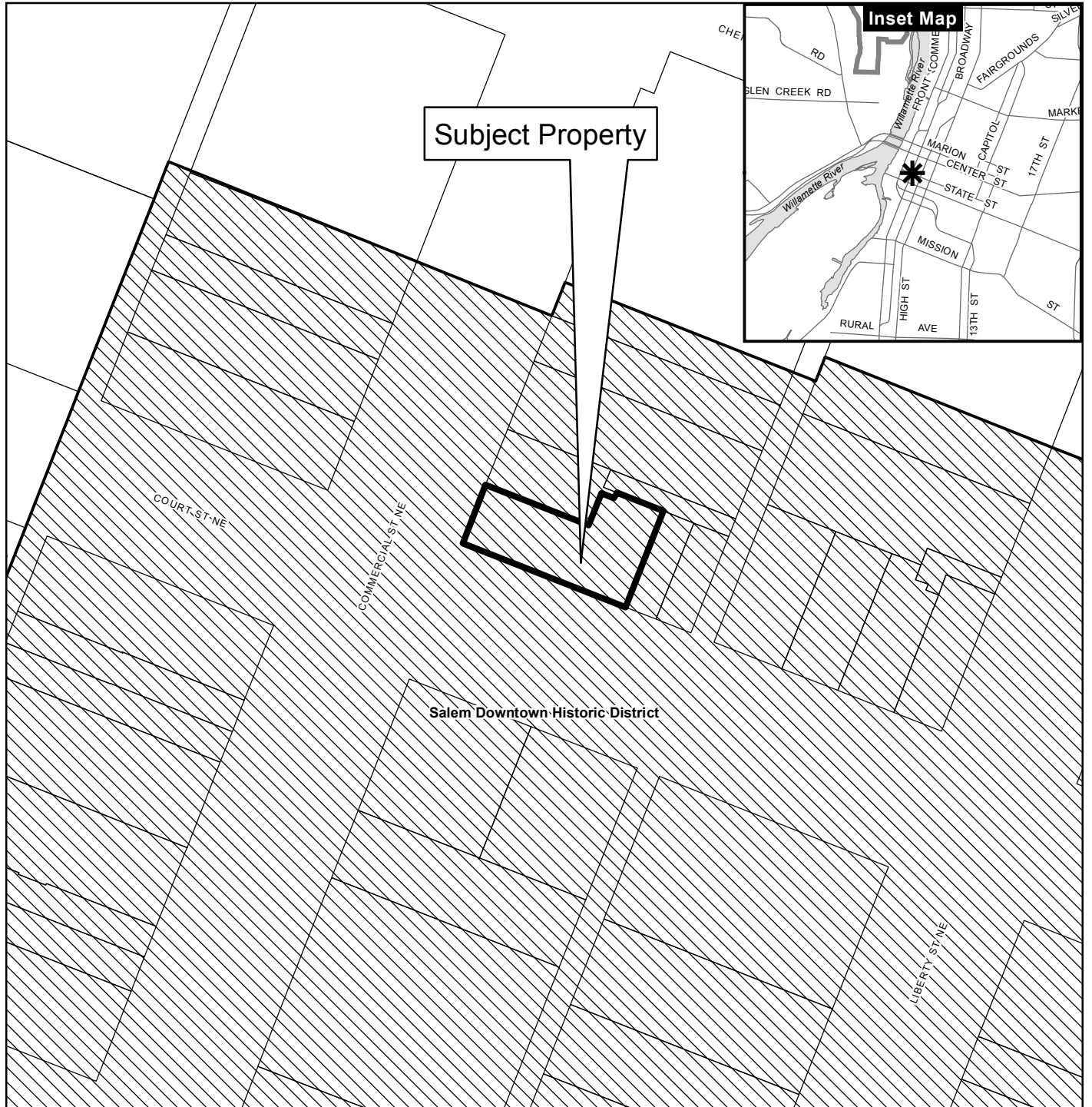

*TTD/TTY telephone 503-588-6439 is also available 24/7*

# Vicinity Map

## 305-321 Court St NE



### Legend

-  Taxlots
-  Urban Growth Boundary
-  City Limits
-  Outside Salem City Limits
-  Historic District
-  Schools
-  Parks

**CITY OF Salem**  
*AT YOUR SERVICE*  
 Community Development Dept.

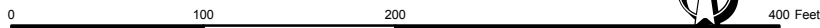

This product is provided as is, without warranty. In no event is the City of Salem liable for damages from the use of this product. This product is subject to license and copyright limitations and further distribution or resale is prohibited.



United States Department of the Interior  
National Park Service

Salem Downtown Historic District  
Salem, Marion County

## National Register of Historic Places

Continuation Sheet

Section number: 7

Page: 26

and Sylvia Dorney purchased the South Eldridge Block in May of 1999. Greenbaum's Quilted Forest continues to occupy the building in 2000.

### **241 - 247 Commercial Street, NE**

*Classification:* Historic Contributing (Listed in National Register, 1982)

*Historic Name:* Benjamin Forstner Store building/South First National Bank Block

*Current Name(s):* Mary Anne's Wordshop

*Year of Construction:* 1887/c.1923

*Legal Description:* 073W22DC08700; Salem Addition, from Lots 2 & 3, Block 49

*Owner(s):* John and Nina Honey, Trustees  
POB 247  
Salem, Oregon 97308

**Description:** This is a two-story unreinforced brick, stucco-faced commercial building of Italianate style designed by Holly A. Cornell. It has a sloping roof with a bracketed cornice with egg-and-dart ornamentation. Two bays on the upper facade contain three double-hung wood sash windows in each bay. Cast iron quoined pilasters frame the bays.

Originally two stores, changes were made to this building by 1923. A central entranceway was established, and the exterior chimneys and ornamental cast iron cresting were removed. A one-story addition on the rear, c.1960, is of concrete block.

The street level is comprised of aluminum-framed display windows. Although not original to the structure, it is a compatible storefront. The transoms have been covered. Both facade corners have cast-iron pilasters with fluted pedestals, a vertical recessed panel, and an "intermediate" capital at the top of the ground-floor windows, culminating in a fluted capital embellished with circles and folded ribbons immediately below the cornice. The building retains its historic qualities and contributes to the character of the downtown district.

**History and Significance:** The South First National Bank Block was constructed during Salem's first period of private redevelopment, which was stimulated primarily by a desire to avoid fire by replacing wood with brick.

Holly A. Cornell (1859-1911) who practiced architecture in Salem for several years designed the building. Cornell is believed to have also designed two residences in Salem: the Werner Breyman Mansion and the Governor Zenas Moody Mansion. Both mansions are now gone. After his Salem practice, Cornell worked as a foreman of several sash and door companies. The South First National Bank Block is believed to be the only identified, extant building designed by Cornell.

Benjamin Forstner and his family were members of the Aurora (Oregon) colony, a Christian cooperative society founded by Dr. William Keil. It was organized at the Rapite Colony in Harmony, Pennsylvania. Forstner is believed to have immigrated to Oregon in 1863. By 1874 he was living in Salem.

### **305 - 321 Court Street**

*Classification:* Historic Contributing

*Historic Name:* Pearce Building

*Current Name(s):* Beauty Salon; Roz John; Green Thumb

*Year of Construction:* 1940

*Legal Description:* 073W22DC08000, Salem Addition, front of Lot 5, Block 32



United States Department of the Interior  
National Park Service

Salem Downtown Historic District  
Salem, Marion County

## National Register of Historic Places

Continuation Sheet

Section number: 7

Page: 27

*Owner(s):* Pioneer Trust Company  
317 Court Street NE, 203  
Salem, Oregon 97301

**Description:** This two-story Modernistic style reinforced concrete building is on the corner of Court and Liberty streets. The corner of the building forms a curve, sweeping from the south-facing facade around to the west-facing facade. A second-floor window bay repeats this corner curve.

This sweeping curvature is the primary focal point of the building. The second-floor facades are flat, rising straight up to the roof edge without a cornice. The window bays are recessed into the primary plane of the facade. These seven second-story window bays are rectangular, recessed areas containing multi-light steel sash windows. The ground floor of both facades has display windows with stucco "bulkheads." The building has retained its original fabric and design and contributes to the historic qualities of the downtown district.

**History and Significance:** The Pearce Building, built in 1940, is a contributing resource in the district because of its association with the commercial development of downtown Salem on the eve of the United States entrance into World War II. The building is also associated with sisters Helen and Dorothy Pearce, who owned this site and had the present Modernistic style building constructed. Helen and Dorothy Pearce acquired the property in 1918 from Wade & Pearce Company.<sup>33</sup>

Robert M. Wade, overland immigrant to Oregon in 1850, founded R. M. Wade & Company in Salem in 1865. George A. Pearce, Helen's and Dorothy's father, began clerking in the Wade store in 1871; he became president and treasurer of the firm when it was incorporated in 1885. Lot Pearce, his younger brother, served as the company bookkeeper for many years. "Wade's," as it was familiarly known, sold agricultural and household equipment from their two-story brick structure (constructed in 1869) at the corner of Commercial and Court streets. The company eventually specialized in farm equipment, carrying all the latest iron tools and equipment manufactured in the 1870s and 1880s and, eventually, tractors. The company also pioneered the use of sprinkler irrigation equipment (known as "Wade Rain"). By the early 1890s, when R.M. Wade established the company headquarters in Portland, Wade's distributed its goods throughout the Willamette Valley and the Pacific Northwest. In 1902 the Salem branch of the business became "Wade-Pearce & Company." From 1915 to 1929, R.M. Wade's son-in-law, Edward Newbegin, presided over the company, followed by his son, Wade Newbegin.<sup>34</sup>

Both Dorothy and Helen Pearce were born in the family home at 267 North Winter Street in Salem, Oregon. Both sisters graduated from Willamette University in the early 1900s. Dorothy, a musician, then attended the New England Conservatory of Music in Boston and also studied music in New York. For many years, Dorothy Pearce maintained a music studio in Salem, taught music, and belonged to several local and national music clubs and associations. Prior to her death in 1966, she served as an officer in the Salem district of the Oregon Music Teachers Association.<sup>35</sup> Her sister Helen Pearce, a student of English, became the first woman graduate of Willamette University (in 1915) to receive her Ph.D. (in 1930 from the University of California, Berkeley, after receiving her master's degree from Radcliffe College in 1926). Helen Pearce taught English at Willamette University from 1920 to 1955. She was a scholar on the subject of Alfred Lord Tennyson. Later in her career, she chaired the English Department at Willamette University. She also

<sup>33</sup> Marion County, deed book, vol. 146, p. 249

<sup>34</sup> Sybil Westenhouse, "Wade-Pearce and Company," *Historic Marion*, Winter 1999, 4; Lillie L. Madsen, "Wade Company Has Grown With Farming in Valley for 100 Years," *Oregon Statesman*, April 1, 1965, sec. 4, p. 37.

<sup>35</sup> "Death Claims Music Teacher," *Capital Journal*, February 22, 1966, sec. 1, p. 3.

United States Department of the Interior  
**National Park Service**

Salem Downtown Historic District  
Salem, Marion County

## National Register of Historic Places

*Continuation Sheet*

**Section number: 7**

**Page: 28**

---

became an authority on local Salem and Oregon history; she co-edited the first ten volumes of "Marion County History." Helen Pearce distinguished herself as the first Oregon woman to preside over Zonta International (from 1938-1940), and was a charter member of the Salem branch of the American Association of University Women. Helen Pearce passed away in 1978.<sup>36</sup> The Pearce family estate retained ownership of the Pearce Building property into the late 1900s.

### **339 Court Street**

*Classification:* Historic Contributing

*Historic Name:* Enright-Halik Building

*Current Name:* Great Harvest Bread Company

*Year of Construction:* c. 1900

*Legal Description:* 073W22DC07800, Salem Addition, front of Lot 5 in Block 32

*Owners:* Great Harvest of Salem Inc.

339 Court Street NE

Salem OR 97301

**Description:** This is a two-story Commercial style unreinforced brick building that includes decorative brickwork and stucco on the second floor exterior wall. The with three one-over-one, double-hung wood sash windows that date from the historic period; the ground floor has multi-light fixed display windows, and wood paneling, that appear to date from the 1980s. A curved canvas awning extends over the sidewalk. While changes to the storefront do affect the overall appearance of the building in part due to its simple architectural detailing on the second floor, the recessed entrance and the use of compatible display windows, provide a similar configuration to the historic period. This building is considered to be a contributing structure in the district.

**History and Significance:** The original owners/occupants Olive and John Enright, and Frank and Emma Halik were associated with commercial and medical developments in Salem in the early years of the twentieth century.

Olive Stanton England acquired the property at 337 Court Street in 1899 (as well as the property at 347 Court). By 1905 she very likely had constructed the present two-story building to replace a one-story building on this site. That year she and her husband, John F. Enright, operated a tailor shop in the building and also resided at the same address (possibly upstairs). Olive and John Enright continued to reside in Salem until the mid-1910s when they apparently moved to Portland, where Olive Enright died in 1936.<sup>37</sup> In 1924 the Enright couple sold their two properties to Frank E. and Emma Halik, and Alvin and Minnie Stewart.

Frank Halik, a native of LaCrosse, Wisconsin, born in 1883, came to Salem in 1918. Halik learned glass blowing as an apprentice and exhibited his skill at fairs in the Midwest, and later on the West Coast. In Salem, he opened and presided over the Halik Electric Company; Emma Halik was vice-president of the company. In 1924 Halik and A.C. Eoff went into partnership as the Halik and Eoff Electric Shop at 337 Court Street. The joining was apparently short-lived. By 1928 Halik Electric Company alone occupied the building at 337 Court and remained there until the depths of the Great Depression in 1932-33. In 1936 "Cherry City Cleaners" was located on the ground floor and radio KSCM rented the second floor. Burroughs Electric

---

<sup>36</sup> "Retired WU professor Helen Pearce Dies," *Capital Journal*, November 13, 1978, 3C.

<sup>37</sup> Marion County, deed book, vol. 70, p. 159; "Salem, Oregon," New York: Sanborn Map Company, 1895, updated to 1914, 1926; Polk, *Salem City Directory*, 1905, 1909-10, 1913, 1917; "Enright," *Oregonian*, August 15, 1936, 11.

**Historic Alteration Review Worksheet**Site Address: 305 Court Street NEResource Status: Contributing  Non- Contributing  Individual Landmark Type of Work Activity Proposed: Major  Minor Chose One: Commercial District  Individual Resource  Public District   
Residential District  Sign **Replacement, Alteration, Restoration or Addition of:****Architectural Feature:**

- Awning  
 Door  
 Exterior Trim, Lintel  
 Other architectural feature  
 Roof/Cornice  
 Masonry/Siding  
 Storefront  
 Window(s) Number of windows: \_\_\_\_\_

**Landscape Feature:**

- Fence  
 Streetscape  
 Other Site feature (describe) \_\_\_\_\_

**New:**

- Addition  
 Accessory Structure  
 Sign  
 Mural  
 Accessibility Ramp  
 Energy Improvements  
 Mechanical Equipment  
 Primary Structure

Will the proposed alteration be visible from any public right-of-way?  Yes  NoProject's Existing Material: Alum and Glass Project's New Material: Alum and Glass**Project Description**

Briefly provide an overview of the type of work proposed. Describe how it meets the applicable design criteria in SRC Chapter 230. Please attach any additional information (i.e., product specification sheets) that will help staff and the HLC clearly understand the proposed work:

Replace existing aluminum storefront, operable transom and entry door facing Commercial Street and another facing Court Street NE. New storefront to be same color aluminum, insulated glass and accessible push and pull handles. Configuration and size to be the same.



Signature of Applicant

12-26-19

Date Submitted/Signed

COMMERCIAL STREET NE

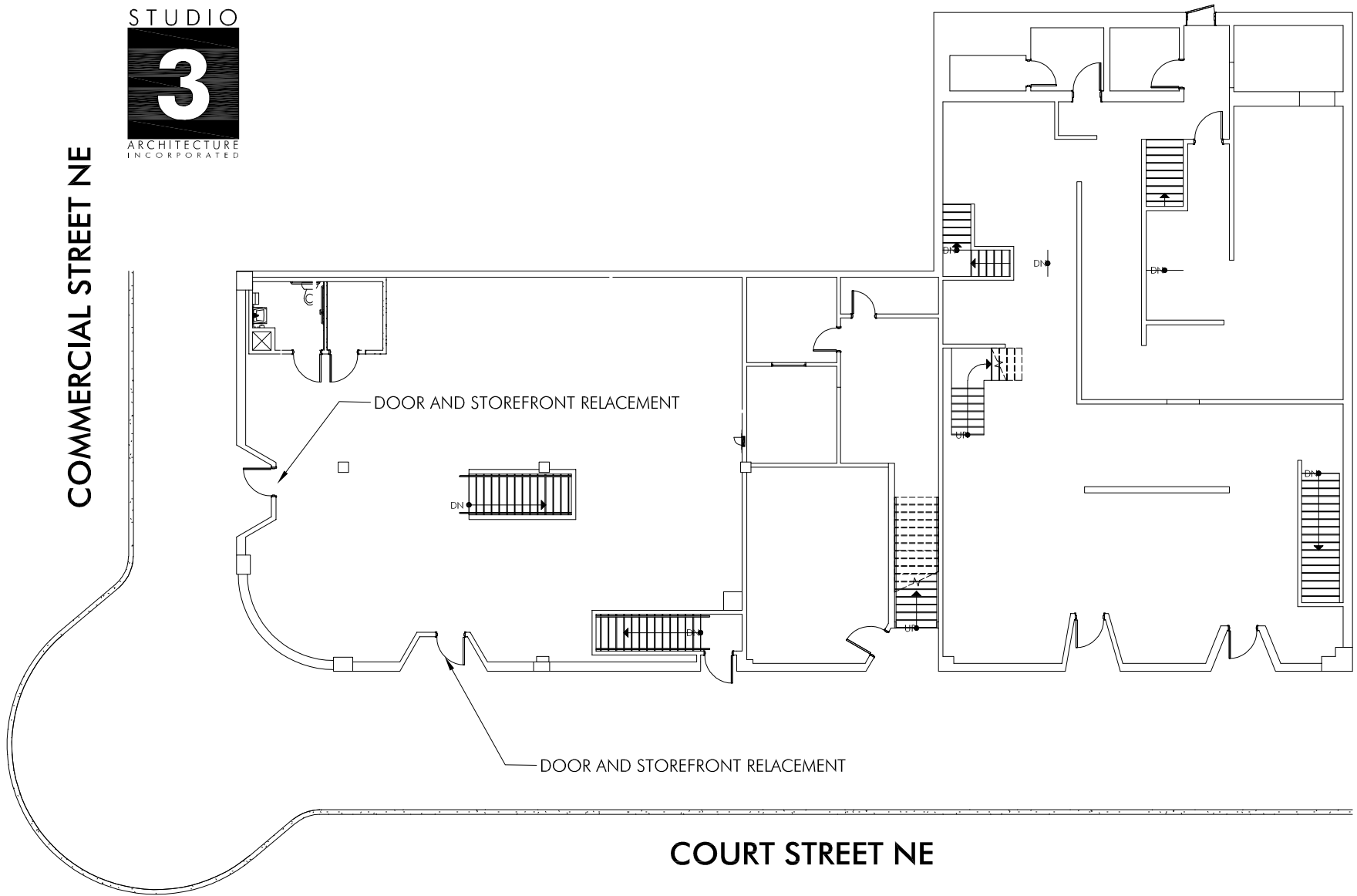

COURT STREET NE

---

---

**PROPOSED ENTRY DOOR REPLACEMENTS - SITE PLAN**  
**305 COURT STREET NE**

15 JAN 2020





COURT STREET IMAGE.  
305 COURT STREET NE  
DOOR, TRANSOME AND SIDE REPLACEMENT





COMMERCIAL STREET IMAGE.  
305 COURT STREET NE  
DOOR, TRANSOME AND SIDE REPLACEMENT

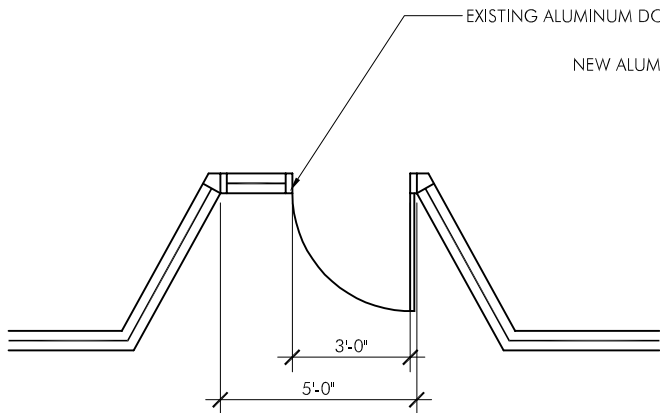

**PLAN-EXISTING**

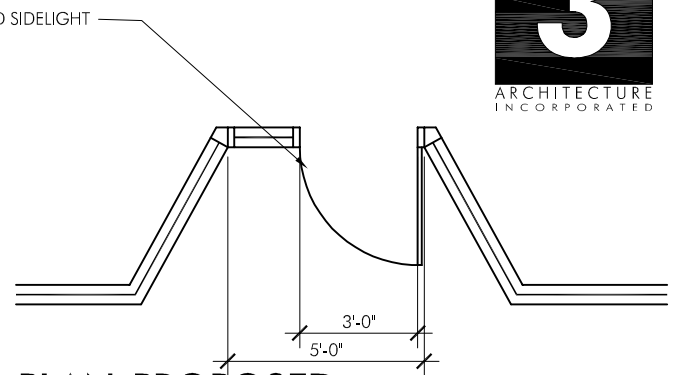

**PLAN-PROPOSED**

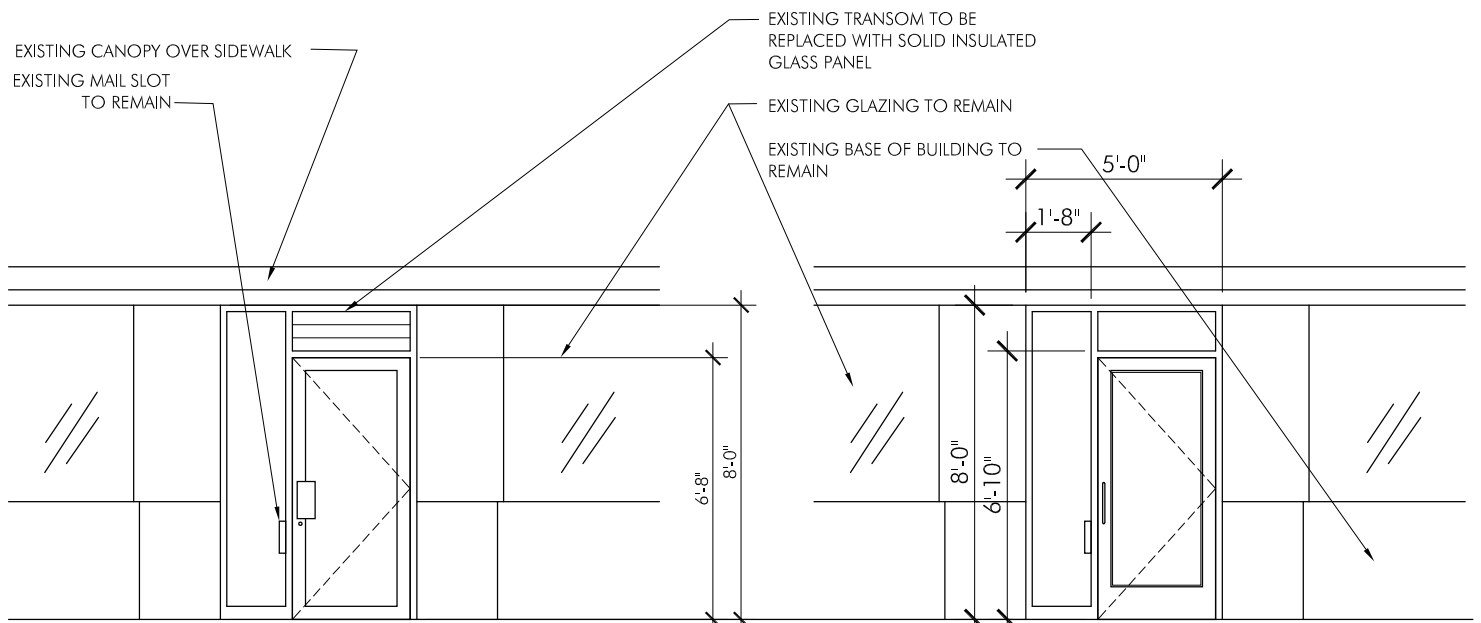

**ELEVATION-EXISTING**

**ELEVATION-PROPOSED**

**PROPOSED ENTRY DOOR REPLACEMENT  
 FACING COURT STREET  
 305 COURT STREET NE**

26 NOV 2019 (R 15 JAN 2020)





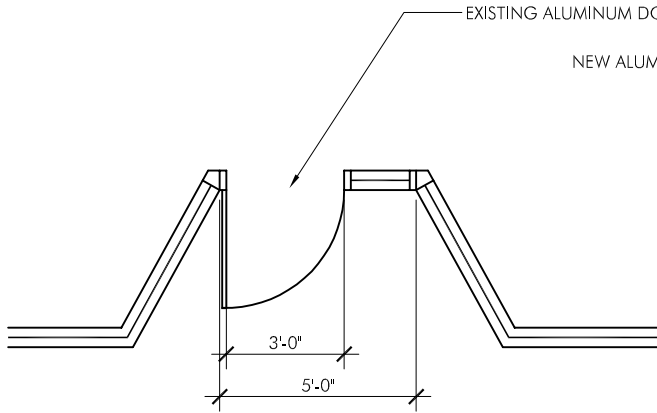

**PLAN-EXISTING**

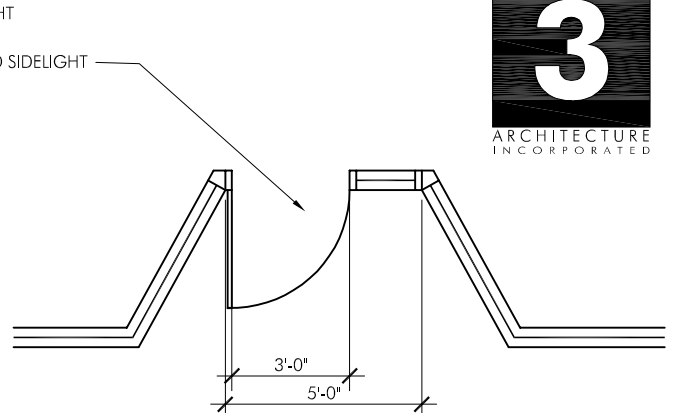

**PLAN-PROPOSED**

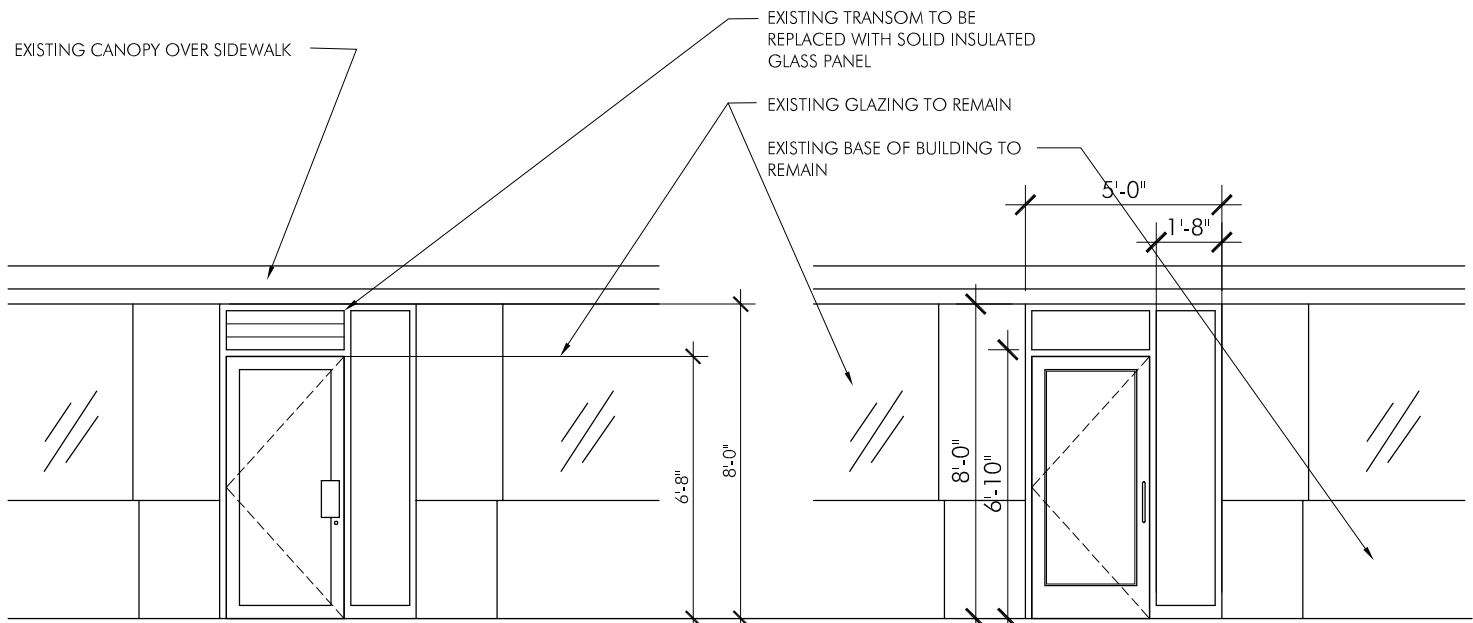

**ELEVATION-EXISTING**

**ELEVATION-PROPOSED**

**PROPOSED ENTRY DOOR REPLACEMENT  
 FACING COMMERCIAL STREET  
 305 COURT STREET NE**

26 NOV 2019 (R 15 JAN 2020)





## Series 3000 XT Storefront— 2" x 4-1/2" thermally efficient storefront system by Oldcastle BuildingEnvelope®

The Series 3000 XT storefront combines superior thermal performance with the simplicity and convenience of a standard storefront. The system incorporates dual polyurethane thermal breaks throughout the system to improve energy efficiency and condensation resistance. The system offers the option of inside or outside glazing along with screw spline or shear block assembly. Designed for 1" infill, the Series 3000 XT Storefront has available glazing adapters and gasket options for infills ranging from 1/4" to 1-1/8".



Target, West Hollywood Gateway, Alameda, CA  
Architect: MBH Architects

### Features

- Overall system dimensions: 2" x 4-1/2"
- Center set glazing configuration
- Sill receptor requires no additional anchoring of sill member
- Superior thermal performance provided through dual polyurethane thermal breaks
- Screw spline and shear block assembly options
- Outside and inside glazing options
- Accommodates zero sight line vents
- Factory painted Kynar 500®/Hylar 5000® finishes, meeting all provisions of AAMA 2605
- Factory anodized finishing
- Dual polyurethane thermal breaks
- 90 and 135 degree outside corners.



Details

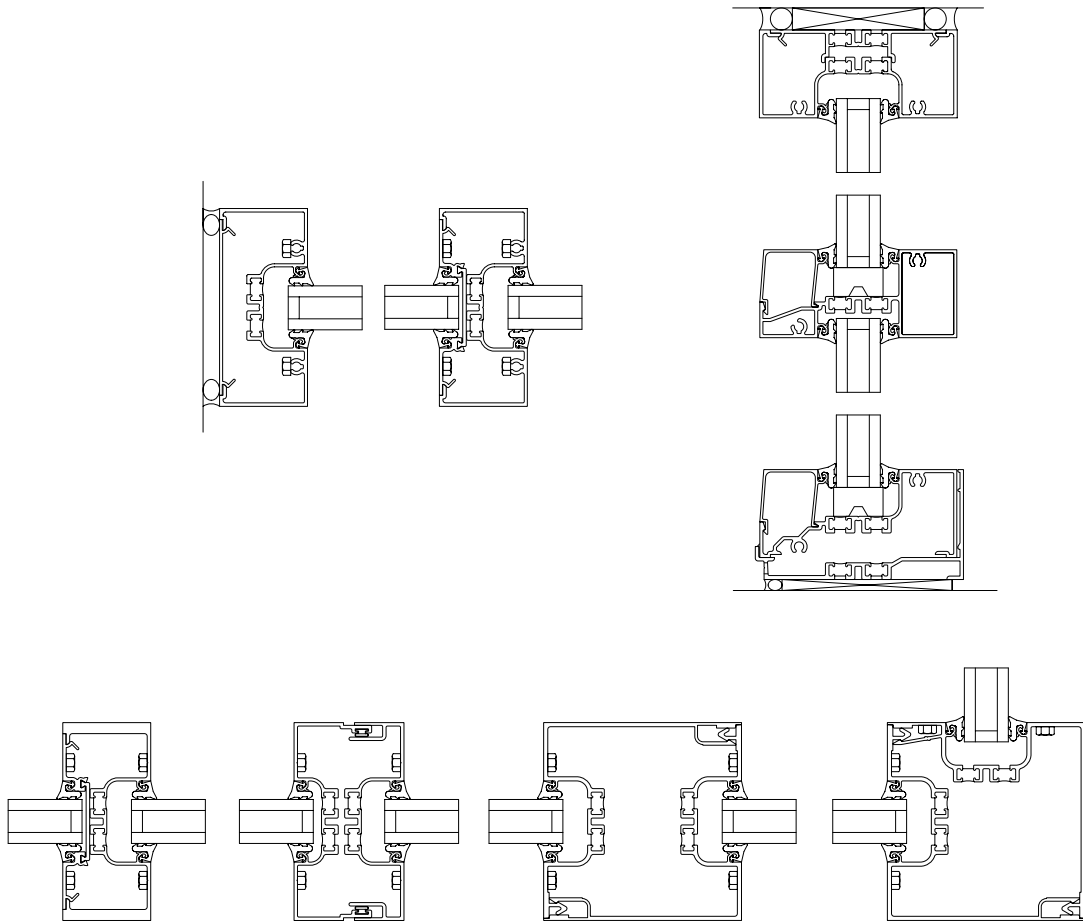

Performance

- Air Infiltration: <.06 CFM/SQ FT (6.24 PSF) per ASTM E283
- Static Water: 10 PSF per ASTM E331
- Deflection Load: 40 PSF per ASTM E330
- Structural Load: 60 PSF per ASTM E330
- STC: 33 (2 x 1/4", 1/2" airspace)  
37 (2 x 1/4" laminated, 1/2" airspace)
- OITC: 27 (2 x 1/4", 1/2" airspace)  
29 (2 x 1/4" laminated, 1/2" airspace)
- Thermal Performance per AAMA 1503 for clear 1" insulating glass:  
U-factor = 0.54  
Frame CRF = 62
- Thermal Performance per AAMA 1503 for Low-E 1" insulating glass:  
U-factor = 0.31  
Frame CRF = 68
- NFRC Certified
- Thermal Performance Characteristics per AAMA 507