

# NOTICE OF DECISION

PLANNING DIVISION  
555 LIBERTY ST. SE, RM 305  
SALEM, OREGON 97301  
PHONE: 503-588-6173  
FAX: 503-588-6005



*Si necesita ayuda para comprender esta informacion, por favor llame  
503-588-6173*

## DECISION OF THE HISTORIC LANDMARKS COMMISSION

**HISTORIC DESIGN REVIEW CASE NO.:** HIS20-24

**APPLICATION NO.:** 20-114436-DR

**NOTICE OF DECISION DATE:** October 19, 2020

**SUMMARY:** A proposal to rehabilitate the front porch and replace the stairs, siding and non-original windows on the front facade of the Denison House (1910).

**REQUEST:** Major Historic Design Review of a proposal to rehabilitate the front porch and replace the stairs, siding and non-original windows on the front facade of the Denison House (1910), a historic contributing building in the Court Chemeketa Historic District in the RD (Single Family Duplex Residential) zone, and located at 1705 Court Street NE - 97301 (Marion County Assessor Map and Tax Lot Number: 073W26AC06200).

**APPLICANT:** Leah McMillan on behalf of David Dahl

**LOCATION:** 1705 Court St NE, Salem OR 97301

**CRITERIA:** Salem Revised Code (SRC) Chapter(s) 230.065 General Guidelines for Historic Contributing Resources

**FINDINGS:** The findings are in the attached Decision dated October 16, 2020

**DECISION:** The **Historic Landmarks Commission APPROVED** Historic Design Review HIS20-24 subject based upon the application materials deemed complete on September 23, 2020 and the findings as presented in this report.

This Decision becomes effective on November 4, 2020. No work associated with this Decision shall start prior to this date unless expressly authorized by a separate permit, land use decision, or provision of the Salem Revised Code (SRC).

### VOTE:

Yes 6          No 0          Absent 3 (French; Mulvihill; Schutte)

Jennifer Maglante-Timbrook, Acting Chair  
Historic Landmarks Commission

The rights granted by the attached decision must be exercised, or an extension granted, by November 4, 2022 or this approval shall be null and void.

Application Deemed Complete:	<u>September 23, 2020</u>
Public Hearing Date:	<u>October 15, 2020</u>
Notice of Decision Mailing Date:	<u>October 19, 2020</u>
Decision Effective Date:	<u>November 4, 2020</u>
State Mandate Date:	<u>January 21, 2021</u>

Case Manager: Kimberli Fitzgerald, [kfitzgerald@cityofsalem.net](mailto:kfitzgerald@cityofsalem.net), 503-540-2397

This decision is final unless written appeal and associated fee (if applicable) from an aggrieved party is filed with the City of Salem Planning Division, Room 320, 555 Liberty Street SE, Salem OR 97301, or by email at [planning@cityofsalem.net](mailto:planning@cityofsalem.net), no later than 5:00 p.m., November 3, 2020. Any person who presented evidence or testimony at the hearing may appeal the decision. The notice of appeal must contain the information required by SRC 300.1020 and must state where the decision failed to conform to the provisions of the applicable code section, SRC Chapter(s) 230. The appeal fee must be paid at the time of filing. If the appeal is untimely and/or lacks the proper fee, the appeal will be rejected. The Hearings Officer will review the appeal at a public hearing. After the hearing, the Hearings Officer may amend, rescind, or affirm the action, or refer the matter to staff for additional information.

The complete case file, including findings, conclusions and conditions of approval, if any, is available for review by contacting the case manager, or at the Planning Desk in the Permit Application Center, Room 305, City Hall, 555 Liberty Street SE, during regular business hours.

<http://www.cityofsalem.net/planning>

***Si necesita ayuda para comprender esta informacion, por favor llame 503-588-6173***

## **DECISION OF THE SALEM HISTORIC LANDMARKS COMMISSION**

**CASE NO.:** Historic Design Review Case No. HIS20-24

**FINDINGS:** Based upon the application materials, the facts and findings in the Staff Report incorporated herein by reference, and testimony provided at the Public Hearing of October 15, 2020 the Historic Landmarks Commission (HLC) finds that the applicant adequately demonstrated that their proposal complies with the applicable provisions of the Salem Revised Code (SRC) 230.065 as follows:

### **FINDINGS**

**Applicable Criteria: 230.065 General Guidelines for Historic Contributing Resources\_**

**Criteria 230.065 General Guidelines for Historic Contributing Resources**

***(a) Except as otherwise provided in this Chapter, the property shall be used for its historic purpose, or for a similar purpose that will not alter street access, landscape design, entrance(s), height, footprint, fenestration, or massing.***

**Finding:** The HLC finds that the applicant is proposing to retain the original residential use of this property. The street access, landscape design, height, footprint and massing will not be altered as a result of this proposal. While the proposed rehabilitation does include a proposal to replace the existing front door and windows which enclose the eastern portion of the porch, these openings will remain substantially the same. The HLC find that this guideline has been met.

***(b) Historic materials, finishes and distinctive features shall, when possible, be preserved and repaired according to historic preservation methods, rather than restored.***

**Finding:** The HLC finds that there are no historic materials or distinctive features original to the structure proposed for removal, reconstruction, or repair and that Guideline 230.065 (b) is not applicable to the evaluation of this proposal.

***(c) Distinctive stylistic features or examples of skilled craftsmanship significance shall be treated with sensitivity.***

**Finding:** The HLC finds that there are no distinctive stylistic features proposed for removal, reconstruction, or repair and Guideline 230.065 (c) does not apply to the evaluation of this proposal.

***(d) Historic features shall be restored or reconstructed only when supported by physical or photographic evidence.***

**Finding:** The HLC finds that the applicant is not proposing to restore or reconstruct any

features based upon physical or photographic evidence and that Guideline 230.065 (d) is not applicable to the evaluation of this proposal.

***(e) Changes that have taken place to a historic resource over the course of time are evidence of the history and development of a historic resource and its environment, and should be recognized and respected. These changes may have acquired significance in their own right, and this significance should be recognized and respected.***

**Finding:** The HLC finds that the applicant is proposing to rehabilitate the porch and porch enclosure in order to correct structural deficiencies. The proposal will result in this portion of the front façade retaining the porch enclosure, an alteration which is not original to the resource, but evidence of its history and development over time. The HLC finds that SRC 230.065 (e) has been met.

***(f) Additions and alterations to a historic resource shall be designed and constructed to minimize changes to the historic resource.***

**Finding:** The HLC finds that the applicant is proposing to rehabilitate the front porch, stairs and eastern porch enclosure. The rehabilitation is necessary to correct design flaws in the porch enclosure that have caused water intrusion and dry rot. Additional design corrections are needed to correct height differences on various sections of the porch floor which in turn requires a rebuild of the steps and railing. The applicant is proposing to replace the non-original windows within the porch enclosure as well as the front door, however the existing door and window openings will be substantially retained. Staff recommends that the HLC find that the reconstruction of the eastern portion of the porch enclosure knee wall, window framing and window and door replacement are compatible with the Denison House. The HLC finds that the proposed reconstruction of the western portion of the front porch, porch steps and rail are designed to minimize changes to the Denison House, and that SRC 230.065(f) has been met.

***(g) Additions and alterations shall be constructed with the least possible loss of historic materials and so that significant features are not obscured, damaged, or destroyed.***

**Finding:** The HLC finds that applicant's proposal is intended to correct structural deficiencies caused by the non-original porch enclosure. The proposed window and door replacement are within the non-original eastern portion of the porch enclosure. The proposed new porch steps, decking and rail, and the new step proposed into the porch enclosure are of a compatible material and scale to the Denison House. The HLC finds that no significant features of the Denison house will be obscured, damaged or destroyed by the proposal and that SRC 230.065(g) has been met.

***(h) Structural deficiencies in a historic resource shall be corrected without visually changing the composition, design, texture or other visual qualities.***

**Finding:** The HLC finds that the applicant's proposal is intended to correct the structural deficiencies caused by the enclosure of the eastern portion of the porch while retaining the existing design and visual qualities of the porch enclosure, which while not original to the



resource, is evidence of its history and development over time. The HLC finds that Guideline 230.065 (h) has been met.

***(i) Excavation or re-grading shall not be allowed adjacent to or within the site of a historic resource which could cause the foundation to settle, shift, or fail, or have a similar effect on adjacent historic resources.***

**Finding:** The HLC finds that the proposal does not include any plans for excavation or regrading, and that Guideline 230.065 (i) does not apply to the evaluation of this proposal

The Historic Landmarks Commission **APPROVES** the proposal.

**VOTE: Yes 6 No 0 Absent 3 (French; Mulvihill, Schutte) Abstain 0**

Attachments: A. Hearing Notice and Vicinity Map  
B. Excerpt from National Register Historic Resource Document  
C. Applicant's Submittal Materials

Prepared by Kimberli Fitzgerald, Historic Preservation Officer



# HEARING NOTICE

## LAND USE REQUEST AFFECTING THIS AREA

*There is a development proposal for the property listed in this notice and shown on the attached map. The City is seeking input from neighbors on the proposal. If you have questions or comments about the proposal, contact the case manager.*

*Esta carta es un aviso sobre una propuesta de desarrollo para la propiedad enumerada y que se muestra en el mapa adjunto. La ciudad está buscando la opinión de los vecinos sobre la propuesta. Si tiene preguntas o comentarios sobre la propuesta, póngase en contacto con nosotros al 503-588-6213*

<b>CASE NUMBER:</b>	Major Historic Design Review Case No. HIS20-24
<b>PROPERTY LOCATION:</b>	1705 Court St NE, Salem OR 97301
<b>SUMMARY:</b>	A proposal to rehabilitate the front porch and replace the stairs, siding and non-original windows on the front facade of the Denison House (1910).
<b>HEARING INFORMATION:</b>	<p><b>DUE TO SOCIAL DISTANCING MEASURES IN PLACE TO HELP STOP THE SPREAD OF THE COVID-19 VIRUS THIS HEARING WILL BE HELD DIGITALLY.</b></p> <p><u>Historic Landmarks Commission, Thursday, October 15, 2020 at 5:30 p.m.</u></p> <p>To view the meeting LIVE on YouTube please visit this link with any computer, tablet, or smart phone: <a href="http://bit.ly/planningpublicmeetings">http://bit.ly/planningpublicmeetings</a></p>
<b>HOW TO PROVIDE TESTIMONY:</b>	<p>Both written and in-person comments will be accepted on this case. Only those participating by submitting written testimony, or testifying during the digital hearing, have the right to appeal the decision.</p> <p><b>To provide written testimony:</b> Direct written comment to the case manager listed below. Staff recommends emailing your comments to ensure receipt before the public hearing.</p> <p><b>To provide testimony digitally at the public hearing:</b> Sign up by contacting Zachery Cardoso at <a href="mailto:zcardoso@cityofsalem.net">zcardoso@cityofsalem.net</a> or 503-540-2347 by <u>Thursday, October 15, 2020 at 3:00 P.M.</u> to receive instructions.</p>
<b>CASE MANAGER:</b>	<b>Kimberli Fitzgerald, Planner III</b> , City of Salem Planning Division, 555 Liberty Street SE, Room 305, Salem, OR 97301. Telephone: 503-540-2397; E-mail: <a href="mailto:kfitzgerald@cityofsalem.net">kfitzgerald@cityofsalem.net</a> .
<b>NEIGHBORHOOD ORGANIZATION:</b>	<p><i>Neighborhood associations are volunteer organizations of neighbors coming together to make neighborhoods the best they can be. They receive notice of land use applications within their boundaries, and they often submit comments on the applications to the City. Neighborhood association meetings are open to everyone. Contact your neighborhood association to get involved:</i></p> <p>Northeast Neighbors (NEN), Nancy McDaniel, Land Use Co-Chair; Phone: 503-585-1669; Email: <a href="mailto:nancmdann@yahoo.com">nancmdann@yahoo.com</a>; Laura Buhl, Land Use Co-Chair; Email: <a href="mailto:buhll@yahoo.com">buhll@yahoo.com</a>.</p> <p>Northeast Neighbors (NEN), Joan Lloyd, Historic Land Use; Email: <a href="mailto:jello879@gmail.com">jello879@gmail.com</a>.</p>
<b>STAFF REPORT:</b>	The Staff Report will be available seven (7) days prior to the hearing and will thereafter be posted on the Community Development website: <a href="https://www.cityofsalem.net/notice">https://www.cityofsalem.net/notice</a> .
<b>ACCESS:</b>	The Americans with Disabilities Act (ADA) accommodations will be provided on request.
<b>CRITERIA:</b>	<p>Salem Revised Code (SRC) Chapter(s) 230.065 General Guidelines for Historic Contributing Resources</p> <p>Salem Revised Code (SRC) is available to view at this link: <a href="http://bit.ly/salemorcode">http://bit.ly/salemorcode</a>. Type in the chapter number(s) listed above to view the applicable criteria.</p>

<b>OWNER(S):</b>	David F Dahl
<b>APPLICANT / AGENT(S):</b>	Leah McMillan on behalf of David Dahl
<b>PROPOSAL REQUEST:</b>	Major Historic Design Review of a proposal to rehabilitate the front porch and replace the stairs, siding and non-original windows on the front facade of the Denison House (1910), a historic contributing building in the Court Chemeketa Historic District in the RD (Single Family Duplex Residential) zone, and located at 1705 Court Street NE - 97301 (Marion County Assessor Map and Tax Lot Number: 073W26AC06200).
<b>HEARING PROCEDURE:</b>	<p>The hearing will be conducted with the staff presentation first, followed by the applicant's case, neighborhood organization comments, testimony of persons in favor or opposition, and rebuttal by the applicant, if necessary. The applicant has the burden of proof to show that the approval criteria can be satisfied by the facts. Opponents may rebut the applicant's testimony by showing alternative facts or by showing that the evidence submitted does not satisfy the approval criteria. A hearing is not a venue to ask questions of staff, the applicant or the decision maker(s) on this case but rather an opportunity to provide testimony to the decision maker(s) on the merits of the land use case; questions about the application, the recommended conditions of approval, or the Planning Administrator's recommendation, should be directed to the Case Manager prior to the hearing.</p> <p>Any participant may request an opportunity to present additional evidence or testimony regarding the application. A ruling will then be made to either continue the Public Hearing to another date or leave the record open to receive additional written testimony. Failure to raise an issue in person or by letter prior to the close of the Public Hearing with sufficient specificity to provide the opportunity to respond to the issue, precludes appeal to the Land Use Board of Appeals (LUBA) on this issue. A similar failure to raise constitutional issues relating to proposed conditions of approval precludes an action for damages in circuit court.</p> <p>Following the close of the Public Hearing a decision will be issued and mailed to the applicant, property owner, affected neighborhood association, anyone who participated in the hearing, either in person or in writing, and anyone who requested to receive notice of the decision.</p>
<b>MORE INFORMATION:</b>	Documents and evidence submitted by the applicant are available for review and paper copies can be obtained at a reasonable cost. You can also find out more information about the status of the proposed application on the City's online Permit Application Center at <a href="https://permits.cityofsalem.net">https://permits.cityofsalem.net</a> . Just enter the permit number listed here: 20 114436
<b>NOTICE MAILING DATE:</b>	September 25, 2020

**PLEASE PROMPTLY FORWARD A COPY OF THIS NOTICE TO ANY OTHER OWNER, TENANT OR LESSEE.**

**For more information about Planning in Salem:**

<http://www.cityofsalem.net/planning>

*It is the City of Salem's policy to assure that no person shall be discriminated against on the grounds of race, religion, color, sex, marital status, familial status, national origin, age, mental or physical disability, sexual orientation, gender identity and source of income, as provided by Salem Revised Code Chapter 97. The City of Salem also fully complies with Title VI of the Civil Rights Act of 1964, and related statutes and regulations, in all programs and activities. Disability-related modification or accommodation, including auxiliary aids or services, in order to participate in this meeting or event, are available upon request. Sign language and interpreters for languages other than English are also available upon request. To request such an accommodation or interpretation, contact the Community*

*Development Department at 503-588-6173 at least three business days before this meeting or event.*





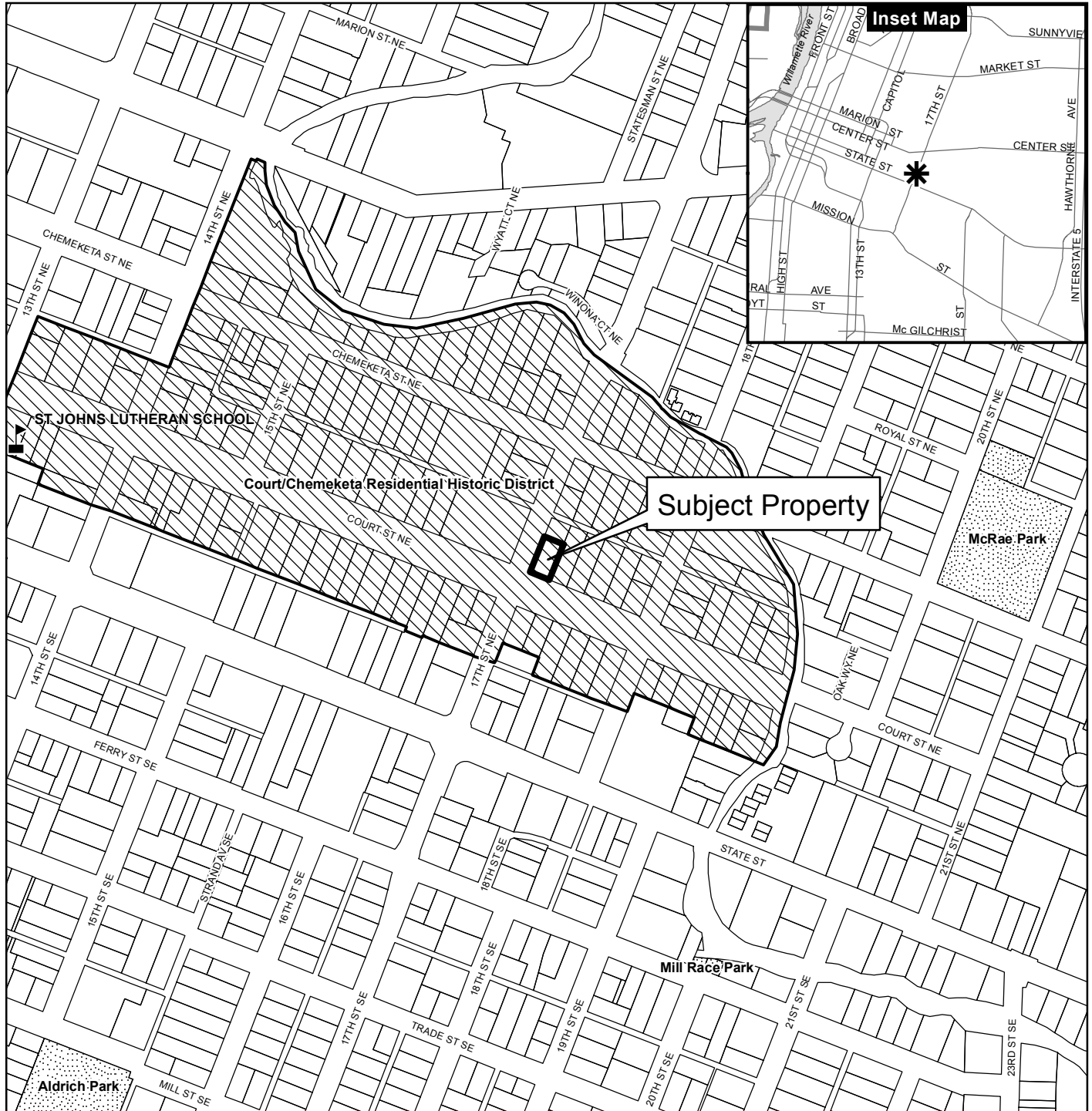

*TTD/TTY telephone 503-588-6439 is also available 24/7*

# Vicinity Map

## 1705 Court Street NE (073W26AC06200)



### Legend

-  Taxlots
-  Urban Growth Boundary
-  City Limits
-  Outside Salem City Limits
-  Historic District
-  Schools

 Parks

**CITY OF Salem**  
*AT YOUR SERVICE*  
 Community Development Dept.

0 100 200 400 Feet



This product is provided as is, without warranty. In no event is the City of Salem liable for damages from the use of this product. This product is subject to license and copyright limitations and further distribution or resale is prohibited.

44. LIZZIE AND JOHN DENISON HOUSE (1910) PRIMARY (Contributing)

1705 Court Street NE; Assessor's Map 26AC073W; 073W-26AC-06200; Tax Lot 1-84400-250

Owner: Donald H. & Florence M. Duncan, 1705 Court Street NE, Salem, Oregon 97301

Description: This nicely proportioned Craftsman Bungalow has been modified several times over the years but has managed to retain much of its original character. It is side-gabled with a large chimney on the west side. The house has a large, front-facing dormer with a set of two double-hung sash windows in it. The porch, recessed beneath the main roof, originally was supported by three sets of free-standing Craftsman piers, but the east half of the porch has been filled in with windows and siding. In 1981, an apartment addition was built on the back (north) side of the house, and the apartment has a separate entry on the east side. Situated on the northeast corner of Court and 17th Streets, this house has a prominent central location in the District.

Cultural Data: The lot it stands on was purchased by the Denisons in 1910, and they are listed as living at this address by 1911. John Denison was a farmer, and early photographs show that there was once a barn-like structure at the rear of the lot. The Denisons sold to Arthur and Hattie Page in 1915. They had been married in 1888 and came to Salem in 1914. He was a farmer, she an active member of the Bungalow Christian Church (cf. commentary on #37), established in 1913 on a site across 17th Street. In about 1925, the Pages built the small bungalow now numbered 246 17th Street (#91) and moved there. In 1926, they rented their large home to Sceva and Lillian Laughlin, who bought it in 1930.

Sceve Bright Laughlin was from 1923 until 1947 a faculty member at Willamette University, working there as professor of economics, sociology, and anthropology. He had been born in Iowa in 1881, educated at Penn College in Iowa and at Harvard and the University of Chicago, and awarded his Ph D at University of Iowa. In Iowa, he had worked as principal of a high school and as superintendent of schools in several small towns. A Quaker, he also taught at the Friends' Boys School in Ram Allah, Palestine. In 1923, he came to Willamette from Park College in Parkville, Mo. While at Willamette, Prof. Laughlin wrote three books. He served as a member of the Salem City Council and was a member of the Grange and of the Farmers Union. He died in 1947 (obituary,, Oregon Statesman Aug. 14, 1947). His widow, Lillian Laughlin, lived on in the house until 1960, when it was sold to the current owners.

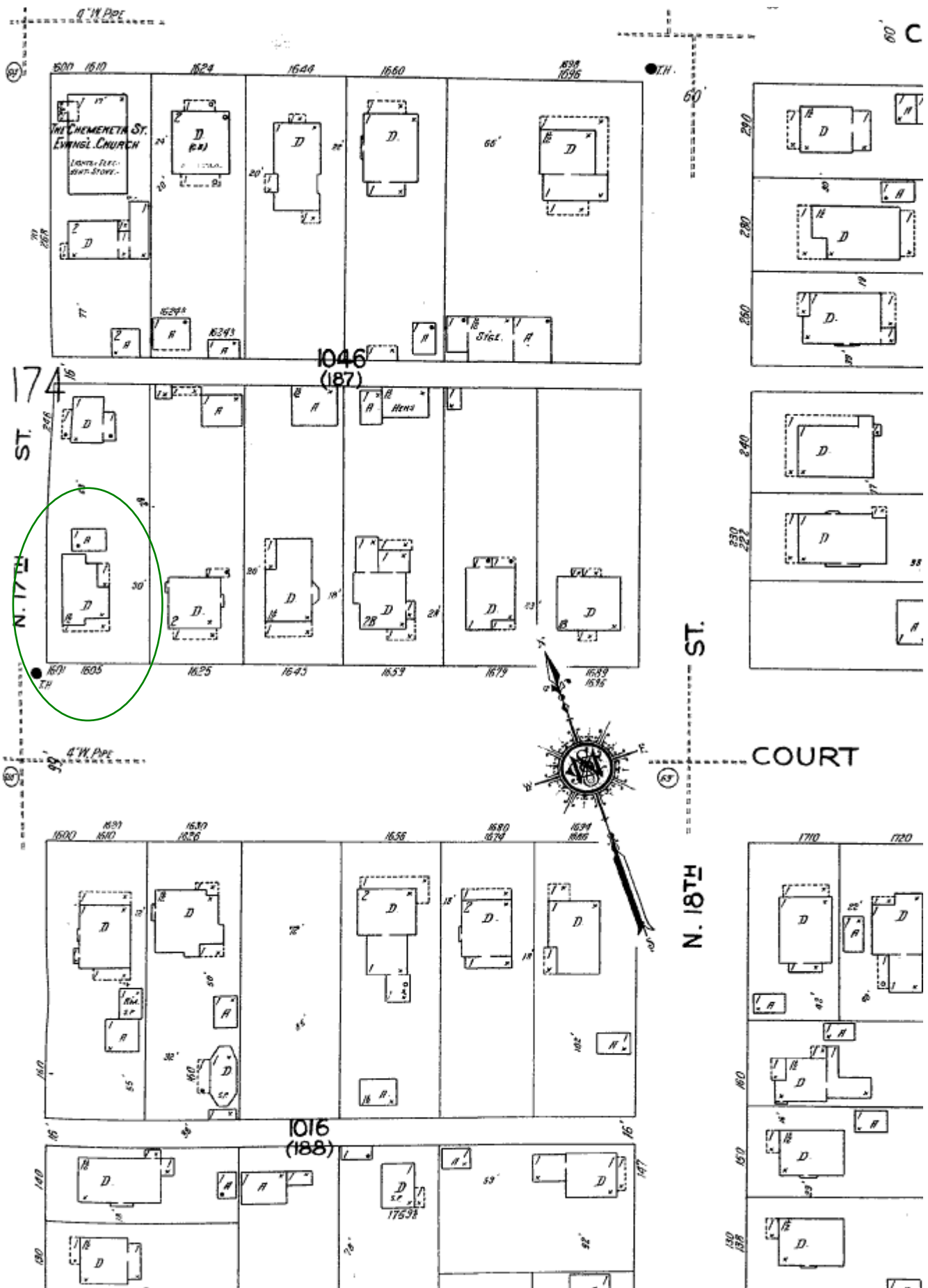

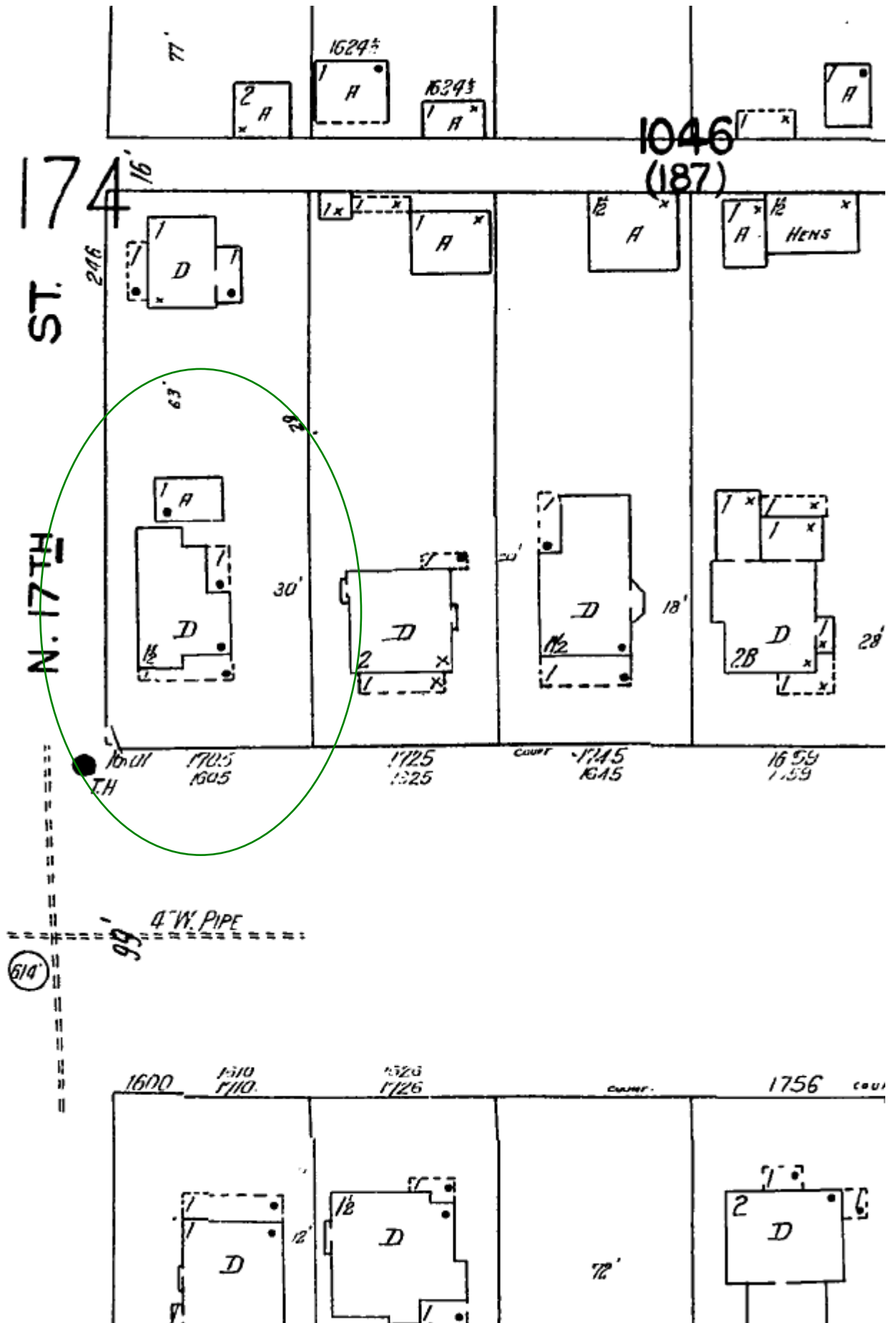



## List of Documents for 1705 Design Review – file number, 20-114436-DR

- I. Historic design review worksheet
  
- II. Porch History
  - Porch history written description (5 pages)
  - 1705 Court Street pre-1915 picture
  - 1705 Court Street circa 1981 picture
  - 1915 Sanborn Map of 1705 Court Street
  - 1926 Sanborn Map of 1705 Court Street
  
- III. Porch Proposal
  - Porch proposal and explanation of compliance (2 pages)
  - 1599 Court Street porch
  - 1474 Court Street porch
  
- IV. Current porch condition
  - picture – west side of 1705 porch
  - picture – center of porch and door
  - picture – porch subfloor projection
  - picture – east porch wall section



### Historic Alteration Review Worksheet

Site Address: 1705 Court Street NE Salem, OR 97301

Resource Status: Contributing  Non- Contributing  Individual Landmark

Type of Work Activity Proposed: Major  Minor

Chose One: Commercial District  Individual Resource  Public District   
Residential District  Sign

#### Replacement, Alteration, Restoration or Addition of:

**Architectural Feature:**

- Awning
- Door
- Exterior Trim, Lintel
- Other architectural feature
- Roof/Cornice
- Masonry/Siding
- Storefront
- Window(s) Number of windows: \_\_\_\_\_

**Landscape Feature:**

- Fence
- Streetscape
- Other Site feature (describe) \_\_\_\_\_

**New:**

- Addition
- Accessory Structure
- Sign
- Mural
- Accessibility Ramp
- Energy Improvements
- Mechanical Equipment
- Primary Structure

Will the proposed alteration be visible from any public right-of-way?  Yes  No

Project's Existing Material: wood Project's New Material: wood

#### Project Description

Briefly provide an overview of the type of work proposed. Describe how it meets the applicable design criteria in SRC Chapter 230. Please attach any additional information (i.e., product specification sheets) that will help staff and the HLC clearly understand the proposed work:

The written explanation of how my proposal complies with SRC Chapter 230 is in the section titled porch alteration and explanation of compliance.

Additional information such as the porch history, photo documentation are also included in this file in the indicated sections. The project elevation drawings are in a separate document.

David F Dahl

Signature of Applicant

Sept 2, 2020

Date Submitted/Signed

## II. Porch History

- Porch history written description (5 pages)
- 1705 Court Street pre-1915 picture
- 1705 Court Street circa 1981 picture
- 1915 Sanborn Map of 1705 Court Street
- 1926 Sanborn Map of 1705 Court Street

### **Current porch features:**

My porch needs to be repaired due to dry rot and water damage that occurred over the years. Some of the damage is due to water intrusion through the horizontal fenestrations or surfaces projections.

South and east walls: The lap siding portion of the wall under the windows is currently set back approximately 2 inches from the apron of the porch, and the plywood subfloor projects out approximately 4 inches from the lap siding. Two inches of this is due to the lap siding wall being set back from the apron and the other two inches consists of a 1 inch covering a trim board and a 1 inch overhang. This part of the plywood is exposed on the exterior and has water damage.

Windows: Both the south and east window area consists of an awning type window that was expanded by adding a series of panes, typically two rows along the bottom, one row along the top, and one or two columns along each side. These are held in place with quarter round where the assembly meets the wall, ceilings and columns.

Outside porch: The floor and the steps of the open porch is slightly lower on the eastern portion than the western portion. This is an indication there may be deterioration.

Apron area: There is a lower section below the column and box like plinths that consists of cedar shingles and with a wide trim board on the top section below the subfloor of the enclosed part of the porch. This feature continues on the open porch to form the knee walls on the front and side of the steps of the open porch area. This feature is denoted as the apron area of the porch in other parts of this history document.

Doug Meltzer of MSC Engineers summarized his observations of the porch structure. His report is in section II.

### **Porch History:**

The 1915, 1926 and subsequent Sanborn fire maps provide information about how the foot print of the porch and the rest of my home changed. I also have an early photograph of my home, which appears to be pre-1915, and later photographs from the late 1970's around the time the apartment at 1707 Court Street was constructed. I did not find other photographs of the front of my home from other time periods. Since there is limited historic information available, this description of the changes and the date of the changes involves a significant degree of speculation and conjecture.

The items mentioned here are the changes or possible changes of which I am aware. There may be other changes that I have not discovered in course of this research.

Porch roof:

Even though the property description on the application to the National Park Service states the following,

The porch, recessed beneath the main roof, originally was supported by three sets of free-standing Craftsman piers, but the east half of the porch has been filled in with windows and siding. ,

the porch is not an original part of my home. A very early photo shows my house had only a gable covered stoop on the east side of the house. This stoop has been removed and replaced by the current porch roof at some point. A copy of this picture is named 1705 Court Street pre 1915.

A 1915 Sanborn fire map shows the front porch of my home with the current footprint. I have not found any pictures that show what features the porch had at that time. The 1915 map of my home indicates the current back office and northern part of the dining room were not constructed at that time.

A 1926 Sanborn map shows the west side of my house reached its current length and by then the double gable roof, which appears to be original, was probably replaced by the current main roof.

The main roof, however, does not cover the front porch. The roof covering the front porch is over framed over the main roof, and this was added at some point after the main roof was constructed. The front dormer may have been constructed at the same time as the front porch roof. It's possible this is also the time the cedar shingles on the apron of the front porch and lower part of my house were added.

Eastern enclosed porch area:

The eastern part of my porch ( approximately 45% of the front elevation) was enclosed at some point later. The enclosed portion had been constructed by 1978 when the 1707 construction began. At this time a partial wall on the east side of my porch and the eastern half (45%) of the south side of the porch was constructed. These walls are approximately 3.5 inches deep, which is narrower than standard exterior walls.

A bank of glass panes sits on each of these walls to serve as windows. The current information about the window assembly is described in the current porch feature section.

The subfloor material, which was originally all tongue and groove wood, projects out into the exterior space. This is different from the open part of porch on the west side. The outer 16 inches of the tongue and groove floor was replaced with plywood in the western 80% of the floor, and the remaining tongue and groove flooring material is separating due to deterioration or settlement. Having the plinth boxes sitting on top of the subfloor is change that was not present originally and different from the western part of the porch.

The door and the trim on the house, apron and knee wall were altered to accommodate the door threshold. The top trim above the door jamb is not square, and the top of door has been altered to fit in the opening. I do not know when or how these changes occurred. The box like plinths under the middle two columns next to the door jamb may have changed as well.

The wide trim board at the top of the apron of the porch breaks and changes levels slightly between the open porch and the enclosed porch. The apron trim on both parts of the porch is narrower than the trim on the rest of my house. The drip ledge between this trim board and the lap siding on the rest of house is not on the apron area of the porch. This may be an indication that the apron of the porch was altered after the porch was constructed.

#### Western Open Porch area:

The floor on the western part of the porch was also lowered around the time the eastern part of the porch was enclosed. The apron on the western part of the porch may have also been changed at this time. The front south facing apron of the open porch is longer on the east side to accommodate the new steps from the lower open western portion to the higher newly enclosed eastern portion of the porch. I do not know if these walls were constructed as part of the enclosure or at a later date.

There is a hand rail on the western side of the porch that runs from the south wall of the house to the box like plinths under the columns on the front of the porch. It seems likely there were hand rails running from the house to the columns on the east side and between the columns in areas where no steps were present.

It also seems likely that originally there was one run of steps from the ground to the porch on one side of the porch or the other. In either case, this is different from the current step configuration. The previous single run of steps probably had hand rails rather similar to those on the west side of the porch rather than the current knee wall apron feature that is on the sides of the lower three steps.

There is also a metal hand rail attached to the middle of the steps from the walkway to the floor of the open porch. This may have been added at the time the porch was enclosed and the change in floor level on the open, western part of the porch or at a later point in time.

The two steps from the walkway to the open porch are pressure treated wood. I don't know whether this occurred when the eastern part of the porch was enclosed or sometime later.

The board between the wide band above the cedar shingle siding and the lap siding is approximately 1 inch higher on the south side of the house on the back of the porch than this board on the west side of my house. This may be an indication of an alteration that occurred.

I have attached two Sanborn maps and two pictures as supporting information.

I. Property Description:

44 Lizzie and John Denison House (1910):

1705 Court Street, NE; Assessor's Map 26AC 7-3W; Tax Lot 84400-250

Owner: Donald Duncan, 1705 Court Street, NE, Salem, OR 97301

Description: This nicely proportioned Craftsman Bungalow has been modified several times over the years but has managed to retain much of its [of its?] original character. It is side-gabled with a large chimney on the west side. The house has a large front-facing dormer with a set of two double-hung sash windows in it. The porch, recessed beneath the main roof, originally was supported by three sets of free-standing Craftsman piers, but the east half of the porch has been filled in with windows and siding. In 1981, an apartment addition was built on the back (north) side of the house, and the apartment has a separate entry on the east side. Situated on the northeast corner of Court and 17th Streets, this house has a prominent central location in the District.

II. Doug Meltzer structural report.

David,

On Wednesday May 6<sup>th</sup>, Doug Meltzer with MSC Engineers Inc. conducted a site visit to your residence to observe the condition and framing method and materials utilized to construct the south entry stoop. The original home was built in 1910, but the stoop was apparently added on in the 1940's. The roof eyebrow is stable and in good repair and it is our advisement that it remain intact and shored to remain in its current position. The three main colonnades that support this roof appear to be in good repair to a height roughly equal to the window sill. From that point downward, several fenestrations project horizontally that retains water over the years and promoted a slow progression of dryrot. The structural aspects of the columns are not visible but when a drill bit was probed in the joints it appeared to be intermittently dryrotten in localized areas and in sound condition elsewhere. More will be learned as it is further exposed during construction. We anticipate that the 1940 vintage window glazing of the entry porch will need to be replaced and reconstructed in kind, suitable for design review for historic value by the City. We suggested that David draw this in a sketch fashion in plan and elevation or present with photographs depicting the "Repairs". It is our understanding that where possible the stoop will be restored in kind with similar materials to resemble the character of the home, suitable to David and review by City.

The floor framing of the porch includes plywood sheathing at the perimeter that projects beyond the sill of the windows and captured moisture which is dryrotten and needs replacement. The original subfloor is 2x decking that is largely intact but will be disrupted when construction proceeds. The perimeter of the stoop is supported off a 6" concrete stem wall and footing perimeter that appears stable but the slope in the stoop to the south suggests that settlement may have occurred over the years. It is not necessary to elevate or modify the footing or stem wall. We would suggest that the 2x4 cripple wall be reconstructed and the floor joists elevated to moderate this slope to a minimum to deflect water (1/2") and not so steep to be awkward such as presently(1.25"). Furthermore the 4x4 posts in the crawlspace under the corner columns are dryrotten on the ends near the base. These posts should be replaced with pressure treated material resilient to future moisture absorption. The steps are in particularly poor condition at this time and need to be rebuilt to match with new material.

I have attached 3 photos representative of the conditions observed. We have numerous photos if needed.

We trust that this summary will suit your present needs to express conditions observed to your contractor. If questions arise or conditions expose areas of concern, I am available to either of you to answer questions.

Thank you,

Douglas S. Meltzer, PE, SE

MSC Engineers, Inc.



t. 503.399.1399

w. [www.msceingineersinc.com](http://www.msceingineersinc.com)

a. 3470 Pipebend Place NE, Ste 120

Salem, Oregon 97301





1705 Court Street pre-1915





1705 Court Street circa 1981

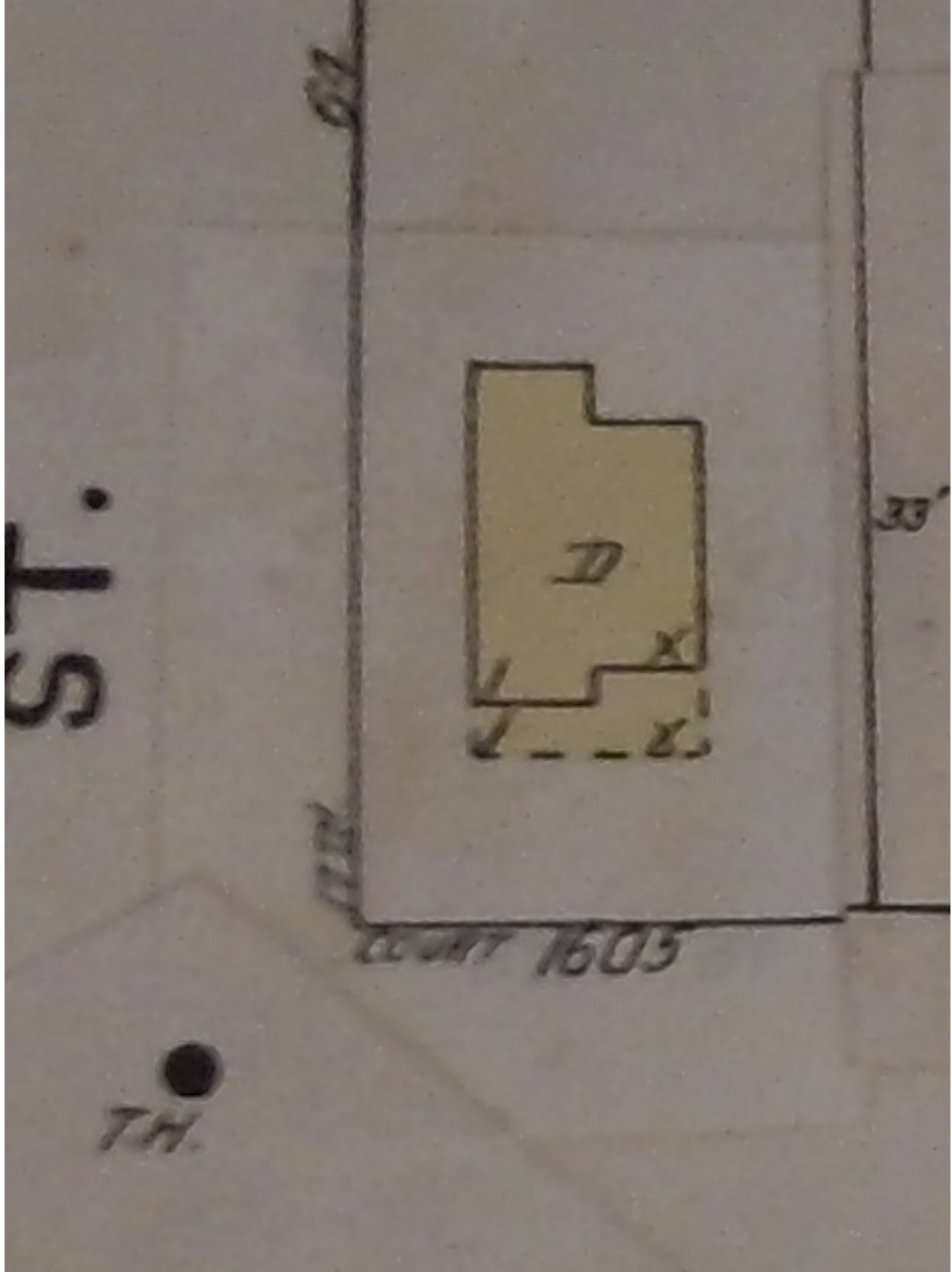

1915 Sanborn Map of 1705 Court Street

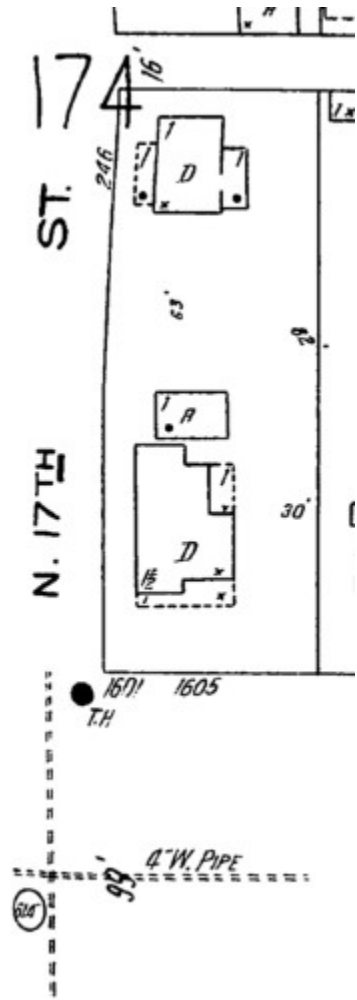

1926/1927 Sheet 175; Sanborn

### III. Porch Proposal

- Porch proposal and explanation of compliance (2 pages)
- 1599 Court Street porch
- 1474 Court Street porch

## **Porch proposal and explanation of compliance (file number 20-114436-DR)**

Changes for this proposal are shown in the elevation and floor plan drawings. This consists of the following items: replacing the current glass window assemblies on the south and east side of the porch with new windows, raising the floor of the open porch, installing hand rails on the south wall of the open porch, installing new steps on from the open porch to the walkway, and replacing the cedar siding on the lower part of the apron with lap siding.

As noted in the description of the porch history, the porch is not the original entrance to my home, the cedar shingle siding is also not an original feature of my home, the eastern part of the porch was enclosed sometime later and the floor and steps of the western part of the porch were most likely changed around the time the eastern part of the porch was enclosed. The proposed alterations are to the features of the porch that have changed not the features that are not known to have changed, such as the columns and the boxes below.

SRC 230.025(d) is the Salem revised code regarding historic porches. The code states that if the original porch repair is not feasible the porch can be replaced or if the porch is not original then the replacement should attempt to replicate the original porch. If the original porch cannot be replicated, then the new porch should use compatible materials and be of compatible design. SRC 230.025(a), which addresses siding, and ORS 230.025(b), which addresses windows, have similar requirements. Since the time of the alterations is unknown, there is not a reliable way to determine whether the porch alterations occurred during the period of significance and would be considered original. The proposed changes incorporate compatible materials and design.

The proposed change to the window areas is to replace the multi panel glass assemblies that were constructed by adding onto awning windows, which do not exist anywhere else in my home, with multi-pane wood casement windows. Currently 8 of the 22 windows in my house are casement windows. The multi pane simulated divided light windows incorporate a window style that exists in my home and maintains the current appearance of the enclosed porch windows.

Raising the floor of the open porch approximately 10 inches from 17 inches above the walkway to 27 inches above the walkway is more consistent with how the porch was first constructed. Since the floor for the open porch needs to have a greater slope than the enclosed porch floor, attempting to have the floor level be the same height for both parts of the porch is not feasible. The open porch floor is below the height of the apron wall in both cases as well. The height of the apron wall is not changing in this proposal. The change in floor height will not be overly conspicuous with the extension of the lower porch wall and addition of hand rails on the wall.

The proposed addition of handrails is an attempt to have the open porch area be compatible with the style of my home and the homes in the area. The west side of the open porch has handrails, and porches from this time period often have handrails. The

style and of the newel posts is also compatible of the of with other homes in the area such the porch of 1599 Court Street.

The cedar siding was added to the lower portion of my house at a later time. My home only had lap siding when it was constructed, so the proposed change is compatible with my home, and this siding material was commonly used for homes built during this time.

Considering the significant changes that were made to my porch and the need for repair due to water damage, I believe these changes are compatible with the my home and the other homes in the district.





1599 Court Street porch





1474 Court Street porch



#### IV. Current porch condition

- picture – west side of 1705 porch
- picture – center of porch and door
- picture – porch subfloor projection
- picture – east porch wall section



westside of 1705 porch





center porch and door





porch subfloor projection

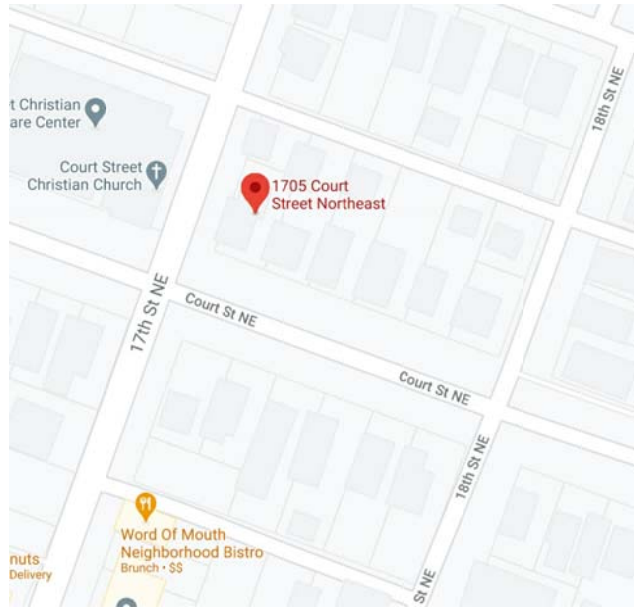

## LOCATION MAP

NTS

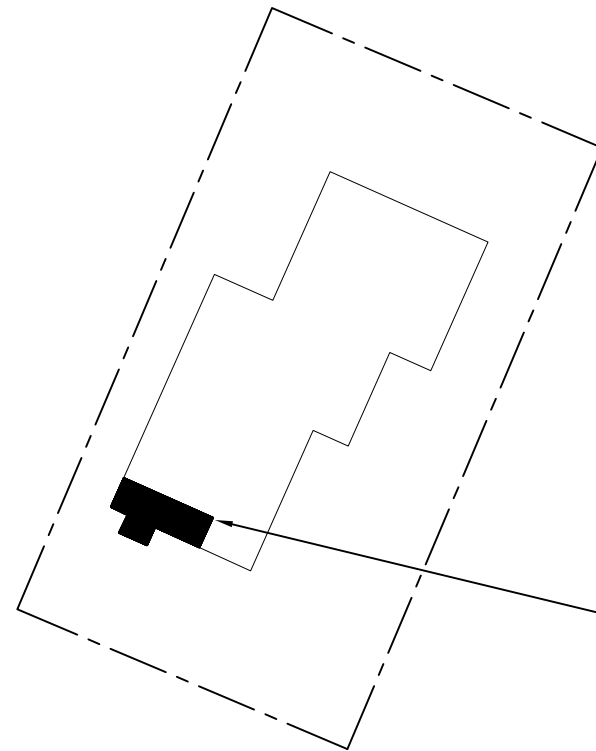

AREA OF WORK  
PORCH, FACADE  
AND ENTRY ONLY

## SITE PLAN

1" = 300'

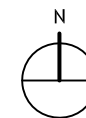

## GENERAL NOTES

1. ALL WORK IS TO COMPLY WITH THE 2017 EDITION OF THE OREGON RESIDENTIAL SPECIALTY CODE AND ANY APPLICABLE BUILDING CODES OF STATE OF OREGON, COUNTY OF MARION OR THE CITY OF SALEM.
2. THE CONTRACTOR IS RESPONSIBLE TO CHECK THE PLANS AND IS TO NOTIFY THE ARCHITECT OF ANY ERRORS OR OMISSIONS PRIOR TO THE START OF CONSTRUCTION.
3. WRITTEN DIMENSIONS SHALL HAVE PRECEDENCE OVER SCALED DIMENSIONS. DO NOT SCALE THE DRAWINGS.
4. THIS HOME IS EXISTING. ANY ALTERATIONS ARE EXTERIOR OR IN NON HEATED SPACES.
5. ALL EXPOSED INSULATION IS TO HAVE A FLAME SPREAD RATING NOT TO EXCEED 25. A SMOKE-DEVELOPED FACTOR NOT TO EXCEED 450 AND CRITICAL RADIANT FLUX NOT LESS THAN 0.12 WATTS PER SQUARE CENTIMETER.
6. INSULATE ALL ACCESS DOOR/HATCHES TO CRAWLSPACES AND ATTICS TO THE EQUIVALENT RATING OF THE WALL, FLOOR, OR CEILING THROUGH WHICH THEY PENETRATE.
7. STAIR RUNS WITH FOUR OR MORE RISERS OR WITH OPEN SIDE, TO HAVE CONTINUOUS HANDRAIL. ALL HANDRAILS SHALL BE AT 34" ABOVE TREAD NOSING AND CONFORM TO ORSC HANDGRIP DIMENSIONS. ENSURE 1 1/2" MINIMUM BETWEEN INDEPENDENT HANDRAILS AND ADJACENT WALL OR GUARDRAIL. ENDS SHALL RETURN TO WALL OR NEWEL OR SHALL HAVE ROUNDED TERMINATIONS OR BENDS. EXTERIOR STAIRS WITH 3 OR FEWER RISERS DO NOT NEED TO HAVE LANDINGS (OTHER THAN THE MAIN EGRESS DOOR).

## PROJECT INFO

073W26AC06200  
ZONE RD

SCOPE OF WORK: EXIST CONTRIBUTING HISTORIC BUILDING. PORCH REMODEL, REPLACED WINDOWS, REPAIR TRIM, SIDING AREA.

NO NEW SQUARE FOOTAGE.

OWNER:  
DAVID DAHL  
1705 COURT ST  
SALEM, OR

ARCHITECT:  
MILL CREEK ARCHITECTURE, LLC  
CONTACT: LEAH McMILLAN  
503.580.4171

CONTRACTOR:  
TBD



1981 PORCH IMAGE



EXISTING HOUSE AND PORCH

## INDEX

- A1.0 SITE AND TITLE
- A2.0 DEMO PLAN
- A2.1 PROPOSED PLAN
- A3.1 ELEVATIONS
- A3.2 SECTIONS
- A3.3 OWS CATALOGUE DETAILS
- DOOR AND WINDOW SPECS



503.580.4171  
leah@millcreekarch.com



1705 COURT ST NE  
PORCH REMODEL  
SALEM, OR

A1.0

9/22/20  
TITLE

If bar is not 1"  
drawing is not to scale.

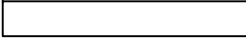
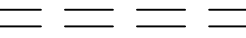

-  NEW WALL
-  EXISTING WALL TO REMAIN
-  DEMO

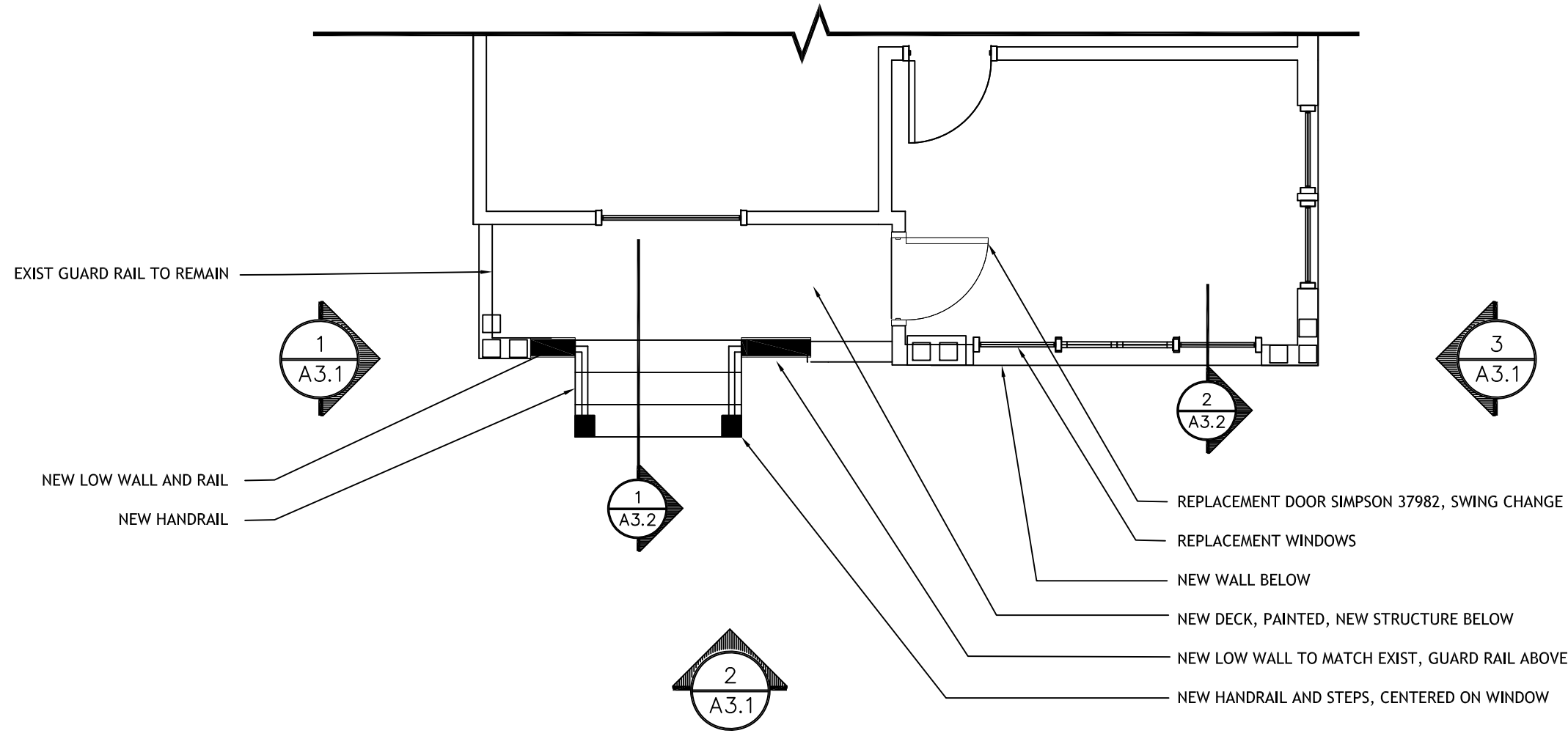

1 PROPOSED PLAN  
1/4" = 1'-0"

1705 COURT ST NE  
PORCH REMODEL  
SALEM, OR

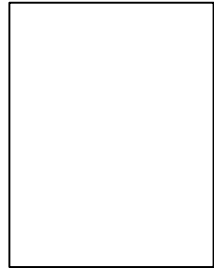

A2.1  
9/22/20  
FLOOR PLAN

If bar is not 1"  
drawing is not to scale.



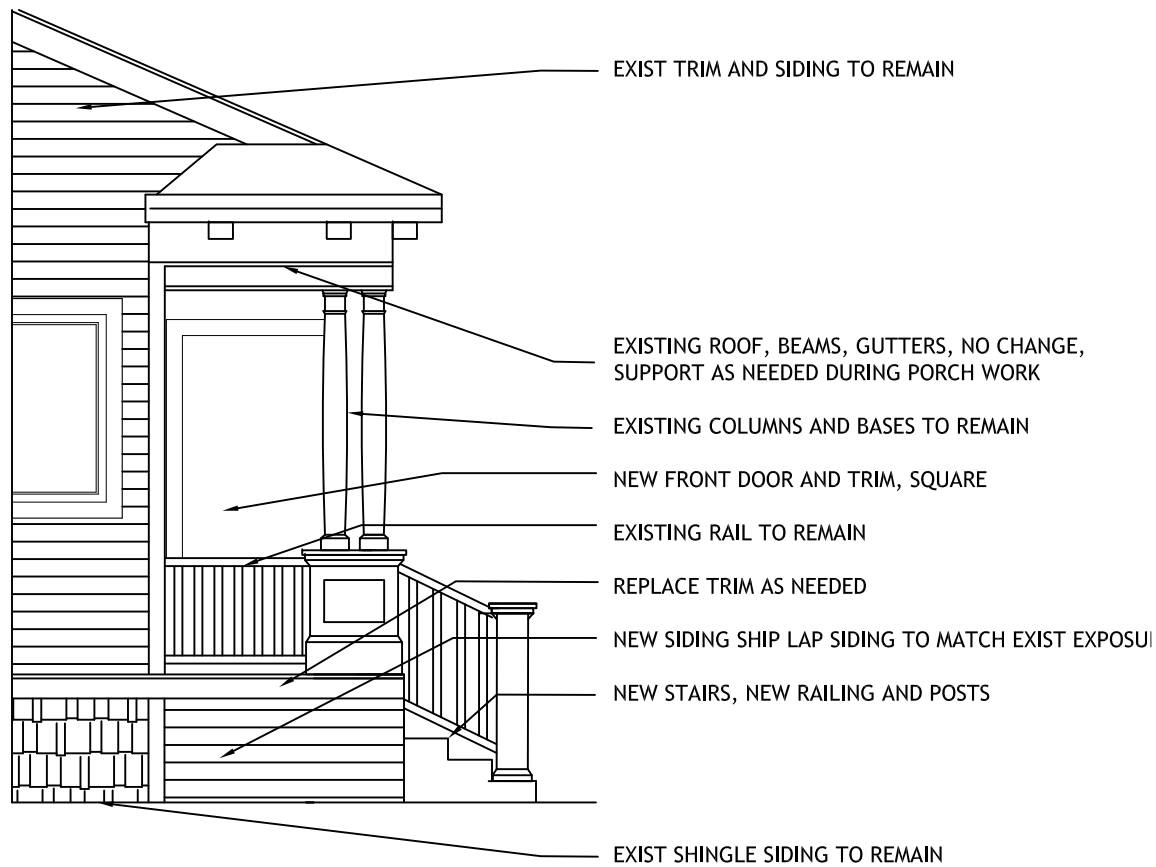

1 ELEVATION  
1/4" = 1'-0"

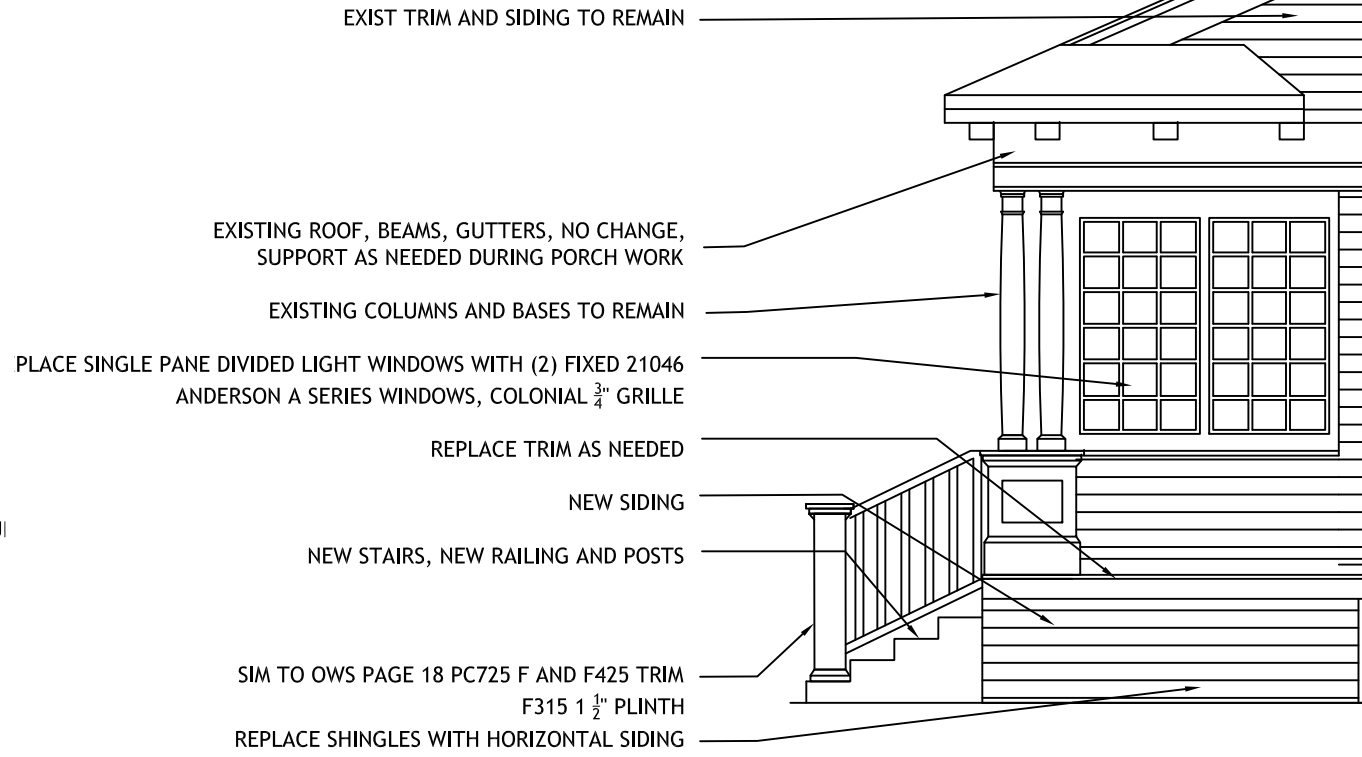

3 ELEVATION  
1/4" = 1'-0"

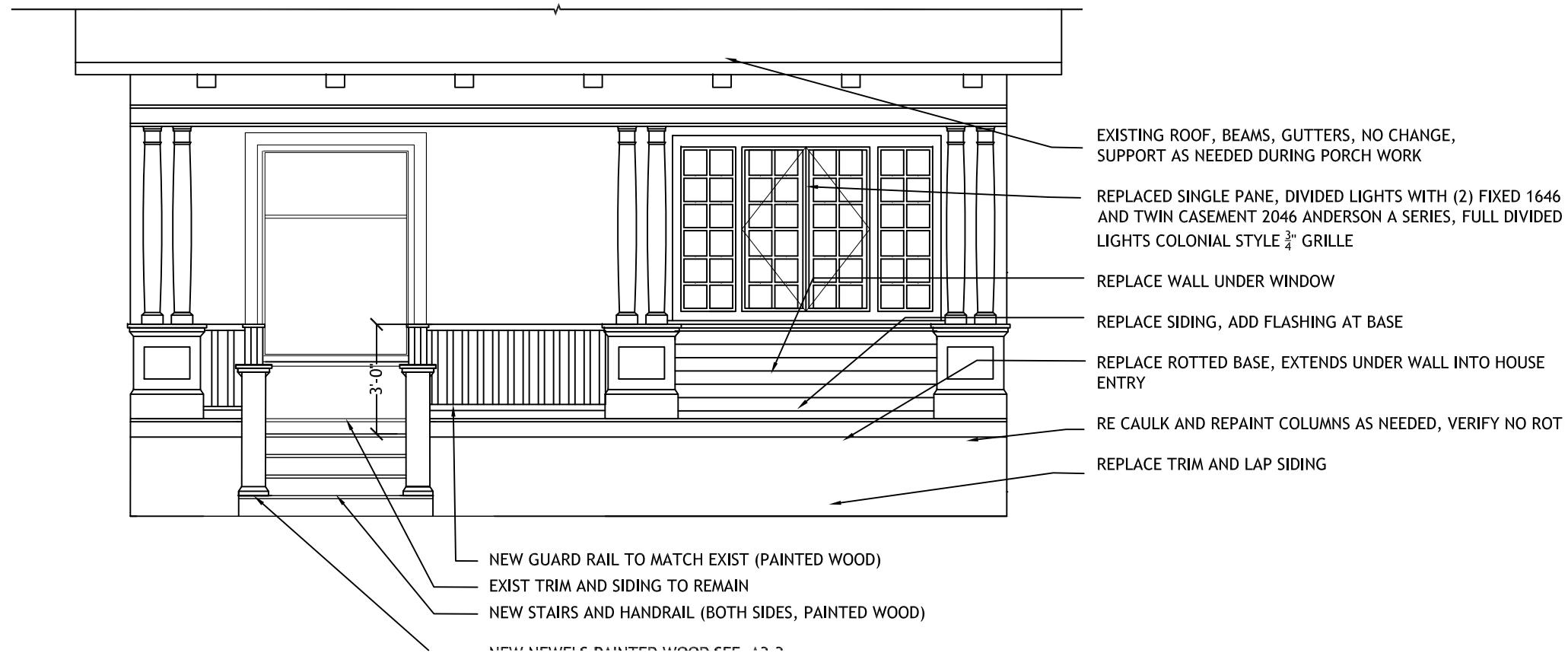

2 ELEVATION  
1/4" = 1'-0"

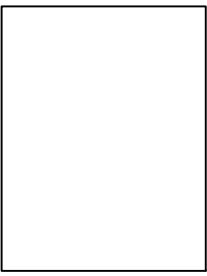

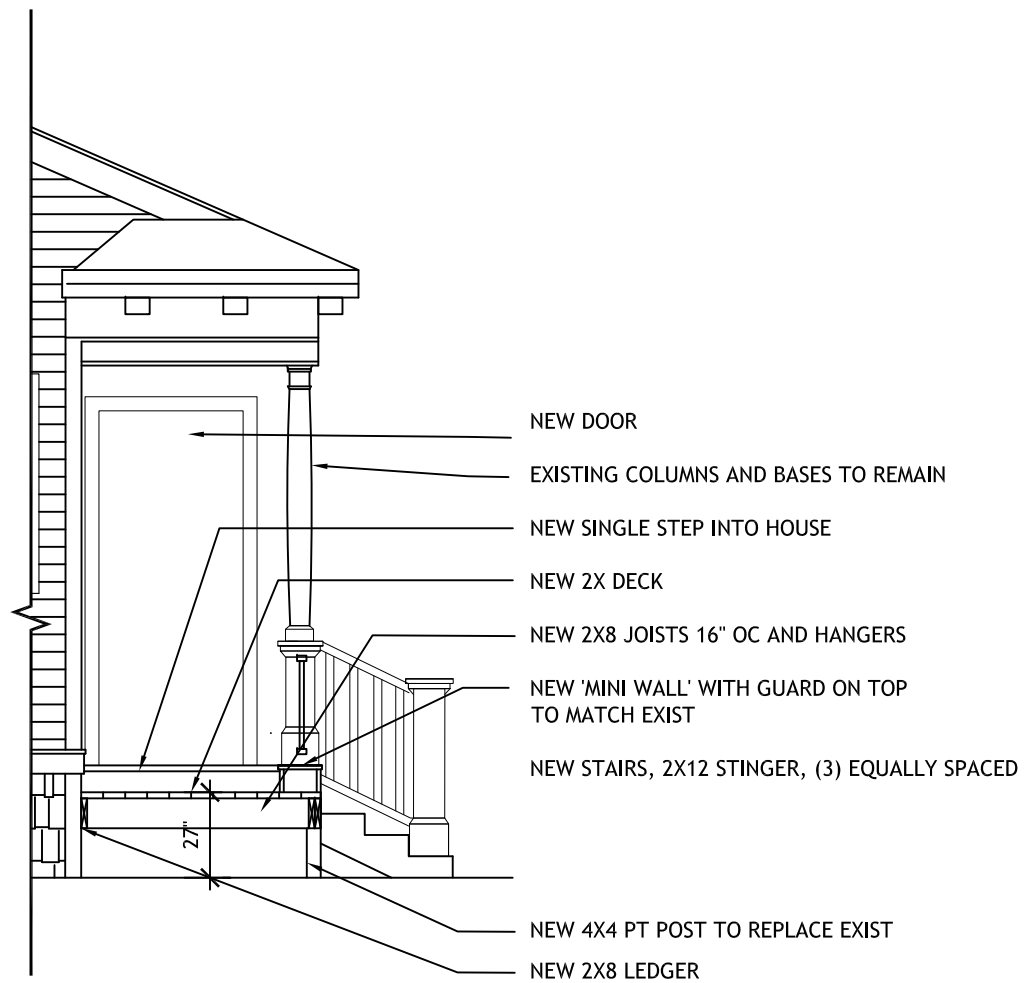

1 SECTION  
 1/4" = 1'-0"

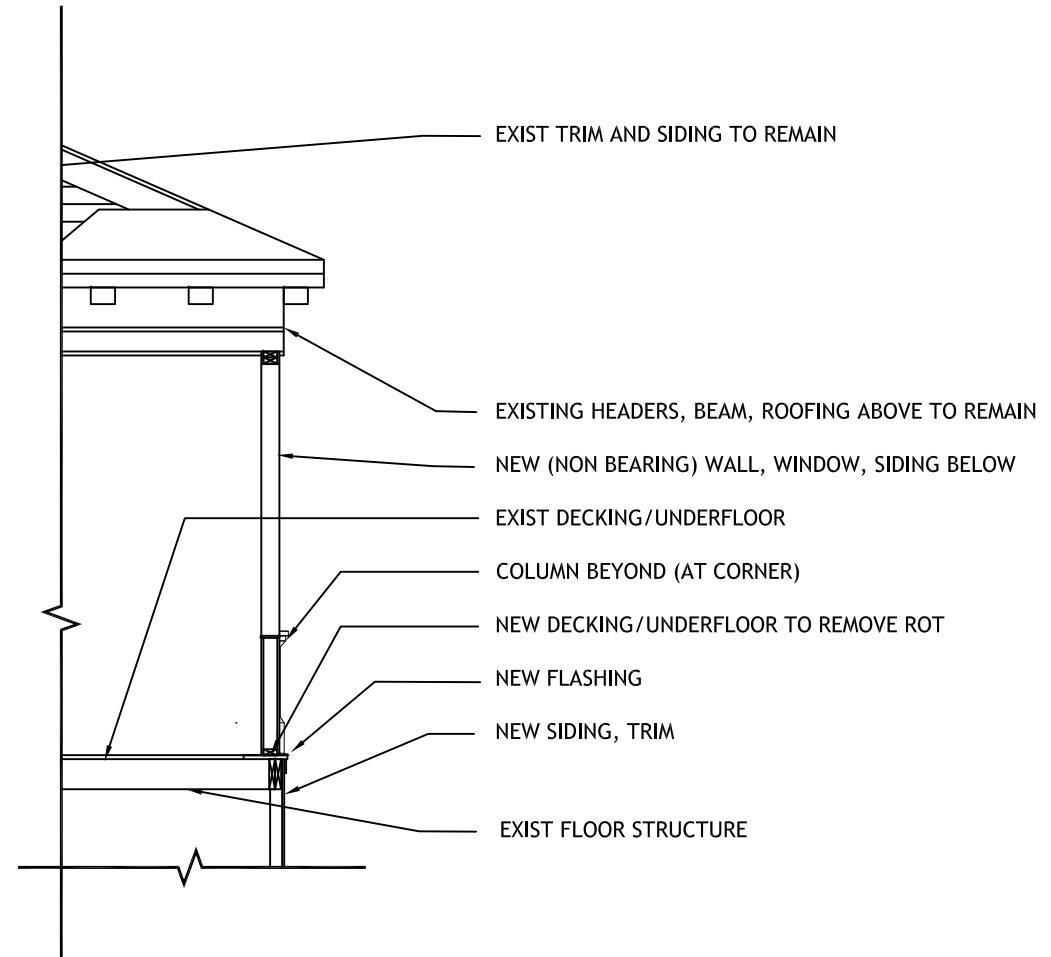

2 SECTION  
 1/4" = 1'-0"

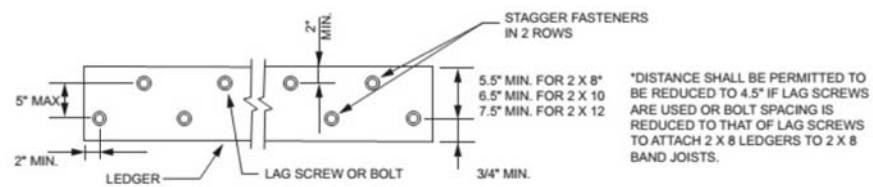

3 LEDGER ATTACHMENT  
 NTS

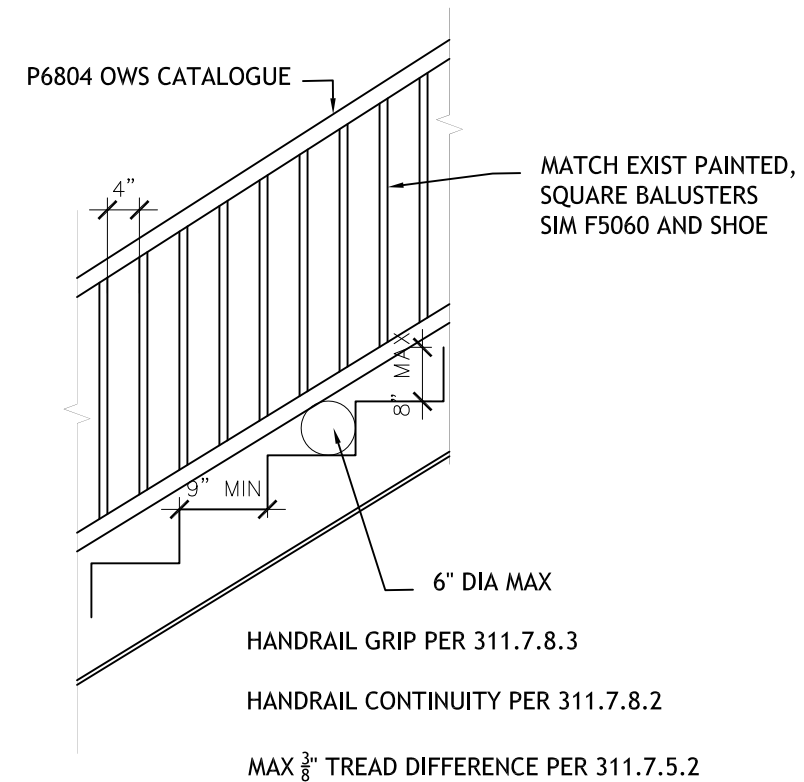

4 STAIR AND HANDRAIL  
 1/2" = 1'-0"



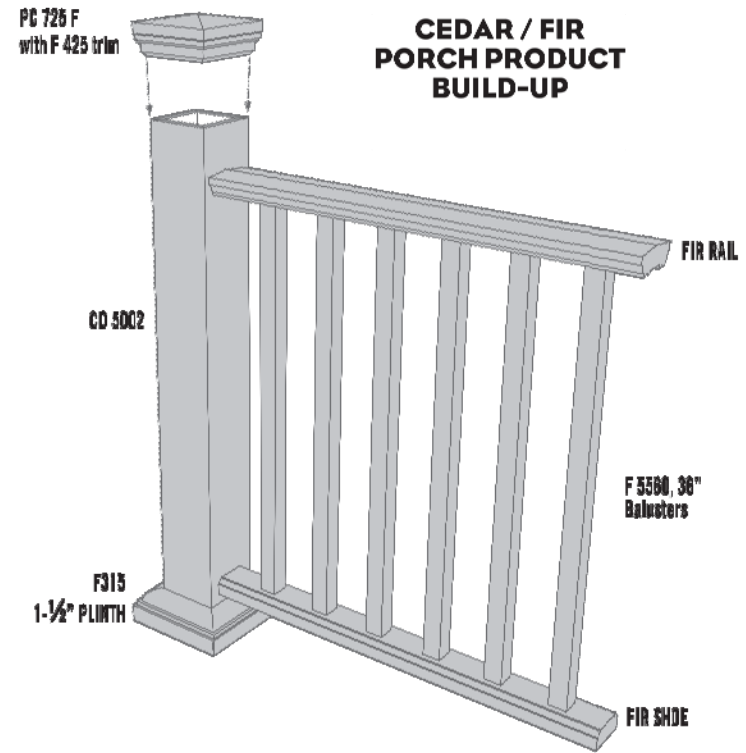

**HAND RAIL**

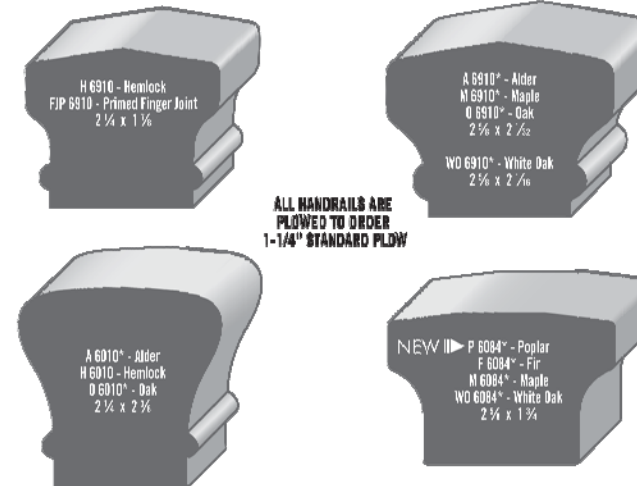

ALL HANDRAILS ARE  
PLOWED TO ORDER  
1-1/4" STANDARD PLOW

\*Vertical rail may have joints.  
Dimensions may change due to manufacturing variations.

**1** **OWS DETAILS**  
NTS



503.580.4171  
leah@millcreekarch.com



1705 COURT ST NE  
PORCH REMODEL  
SALEM, OR



**A3.3**  
9/22/20  
SPEC



If bar is not 1"  
drawing is not to scale.

ARCHITECTURAL AUTHENTICITY,  
UNPARALLELED PERFORMANCE



# A-SERIES WINDOWS

## DOUBLE-HUNG WINDOWS

Double-hung windows have two operating sash (glass panels) that move up and down allowing for ventilation on the top, bottom or both. With a tilt-in feature for easy cleaning, these windows are ideal around patios, decks and walkways.

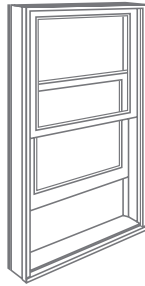

## CASEMENT & AWNING WINDOWS

Casement windows are hinged on the side and crank open outward to the left or right allowing for full top to bottom ventilation. Awning windows are hinged on the top and open outward from the bottom, allowing for ventilation and protection from the rain. Both styles can be grouped in stunning combinations for a better view.

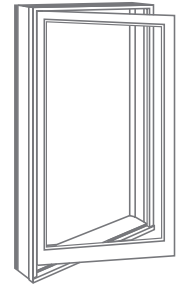

## SPECIALTY WINDOWS

Specialty windows are stationary (non-opening) windows characterized by their special shapes, including curves and dramatic angles. They can make a signature statement in your home or provide a delicate lighting accent.

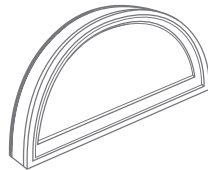

## VENTING & STATIONARY TRANSOM WINDOWS

Transom windows can be used in window combinations or placed above doors to let in light and fresh air while adding style and curb appeal. Available as a venting window that is hinged at the top and opens outward or as a stationary (non-operating) window.

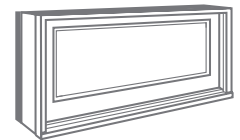

# A-SERIES FRENCHWOOD® PATIO DOORS

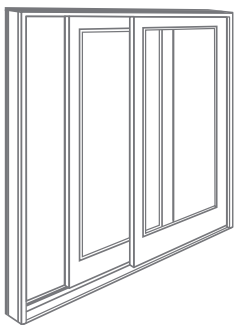

## FRENCHWOOD GLIDING PATIO DOORS

Gliding patio doors have at least one door panel that glides horizontally past another door panel. They fit into tighter spaces than hinged doors because their panels don't interfere with your room or patio.

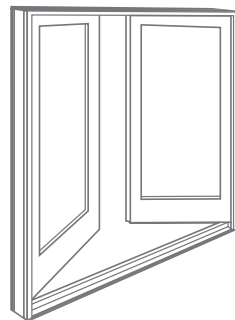

## FRENCHWOOD HINGED PATIO DOORS

Inswing patio doors open into the interior of your home, saving room for smaller exterior areas such as balconies or patios. Outswing patio doors open outward, giving you more space inside your home. Both doors feature traditional French styling that goes well with any home style.



## FRENCHWOOD TRANSOMS & SIDELIGHTS

Transoms go above a door while sidelights flank one or both sides of the door. Alone or combined, they can turn your doorway into a focal point while letting more natural light into your home's entryway.



All windows and patio doors are available in custom sizes.

# OPTIONS TO FIT ANY HOME

A-Series windows and doors provide you with a wide palette of exterior colors, wood species and interior finishes to help you bring your personality and taste to your home.

## EXTERIOR COLORS



Select any combination of colors, shown here, for your exterior frame, sash and trim.

## INTERIOR WOOD SPECIES



## FACTORY-FINISHED INTERIORS

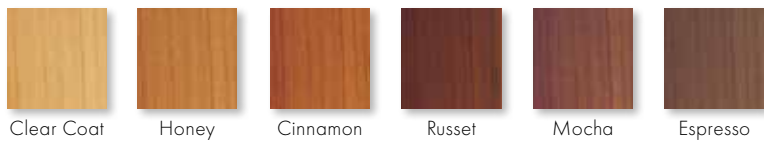

Shown on pine. Available on pine, maple and oak only.

## INTERIOR PAINTED OPTIONS

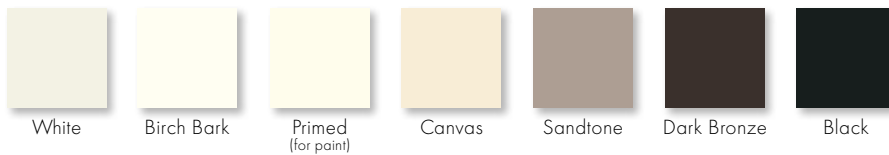

Available on pine. Additional colors to match all 11 exterior colors are also available, contact your Andersen supplier.

## EXTERIOR TRIM

Exterior trim adds a finishing touch to your windows and is often essential in achieving authentic architectural style. To see more trim options and to design your window, visit [andersenwindows.com/design-tool](http://andersenwindows.com/design-tool).



2" brick mould, shown in canvas



3 1/2" or 4 1/2" flat casing, shown in Sandtone



3 1/2" or 4 1/2" flat casing with extended sill nose, shown in prairie grass

\*Actual wood species is either Sapele or Sipo, both non-endangered species grown in Africa, with color and characteristics similar to Central American mahoganies. Interiors are unfinished unless a stain or paint option is specified. Naturally occurring variations in grain, color and texture of wood make each window one of a kind. Printing limitations prevent exact replication of colors and finishes. Please see your Andersen supplier for actual color and finish samples.

# DETAILS THAT MAKE AN IMPACT

Our A-Series hardware\* options make sure you have the style needed to enhance or complement the overall design of your home.

## STANDARD



Lock & Keeper

## Double-Hung



Hand Lift

## TRADITIONAL



Bar Lift



Finger Lift

Antique Brass | Black | Bright Brass  
 Brushed Chrome | Distressed Bronze | Distressed Nickel  
 Gold Dust | Oil Rubbed Bronze | Polished Chrome  
**Satin Nickel** | Stone | White

## Casement & Awning

### TRADITIONAL FOLDING



**Antique Brass** | Black | Bright Brass | Brushed Chrome  
 Distressed Bronze | Distressed Nickel | Gold Dust  
 Oil Rubbed Bronze | Polished Chrome | Satin Nickel  
 Stone | White

### CONTEMPORARY FOLDING



**Black** | Bright Brass | Gold Dust  
 Oil Rubbed Bronze | Satin Nickel | Stone | White

Bold name denotes finish shown.

## HARDWARE FINISHES



Antique Brass | Black | Bright Brass | Brushed Chrome | Distressed Bronze | Distressed Nickel | Gold Dust | Oil Rubbed Bronze | Polished Chrome | Satin Nickel | Stone | White

\*Hardware sold separately.

Distressed bronze and oil rubbed bronze are "living" finishes that will change with time and use. Printing limitations prevent exact finish replication. See your Andersen supplier for actual finish samples.

# ARCHITECTURALLY AUTHENTIC GRILLES

Andersen® A-Series windows and patio doors offer a variety of grille types and grille patterns, making it easy to fit both your style and your home's. For a signature look, we'll also work with you to create custom grille designs.



Specified Equal Light



Specified Equal Light



Specified Equal Light



Custom

To see all the standard patterns available for a specific window or door, see your Andersen supplier.

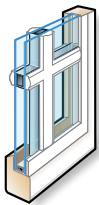

Permanent exterior  
Permanent interior  
with spacer



Permanent exterior  
Permanent interior

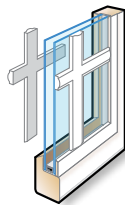

Permanent exterior  
Removable interior

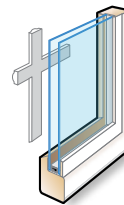

Removable interior



Finelight™  
Grilles-  
Between-  
the-Glass®

## FULL DIVIDED LIGHT

Permanently applied to the interior and exterior of your window with a spacer between the glass.

## SIMULATED DIVIDED LIGHT

Permanent grilles on the exterior and interior with no spacer between the glass. We also offer permanent exterior grilles with removable interior grilles.

## CONVENIENT CLEANING OPTIONS

Removable interior grilles come off for easy cleaning. Finelight grilles-between-the-glass are installed between the glass panes and feature a contoured ¾" or 1" profile.

## Grille Bar Widths



¾"



7/8"



1 1/8"



2 1/4"

Cross section of grilles showing standard widths and profiles.

Our 2 ¼" wide grille can be positioned horizontally across the center of a casement window to simulate the look of a double-hung window.

# SCREEN OUT THE INSECTS, NOT THE VIEW

Optional insect screens are available for all A-Series products. Patio doors feature conventional Andersen fiberglass insect screens. For windows, choose aluminum insect screens, or TruScene® insect screens that provide a clearer view, help bring the outdoors into your home and are less noticeable from the street.



\*7/8", 1 1/8" and 2 1/4" not available in Finelight grilles-between-the-glass.



# BEST-IN-CLASS GLASS

Glass can affect energy efficiency more than any other part of a window or patio door — and not all glass performs the same. Some types of glass do a better job at insulating your home. Others provide greater clarity. You can even choose glass to filter out specific kinds of light. Andersen offers one of the industry’s widest arrays of glass options, enabling you to find the right choice for your climate and your home. Choose from these High-Performance glass options.

GLASS		ENERGY		LIGHT	
		U-Factor <small>How well a product prevents heat from escaping.</small>	Solar Heat Gain Coefficient <small>How well a product blocks heat caused by sunlight.</small>	Visible Light Transmittance <small>How much visible light comes through a product.</small>	UV Protection <small>How well a product blocks ultraviolet rays.</small>
<b>SmartSun™</b>	Thermal control similar to tinted glass, with visible light transmittance similar to Low-E4 glass.	● ● ● ○	● ● ● ●	● ● ● ○	● ● ● ●
<b>SmartSun with HeatLock® Coating</b>	Applied to the room-side surface, it reflects heat back into the home and improves U-Factors.	● ● ● ●	● ● ● ●	● ● ○ ○	● ● ● ●
<b>Low-E4®</b>	Outstanding overall performance for climates where both heating and cooling costs are a concern.	● ● ● ○	● ● ● ○	● ● ● ○	● ● ● ○
<b>Low-E4 with HeatLock Coating</b>	Applied to the room-side surface, it reflects heat back into the home and improves U-Factors.	● ● ● ●	● ● ● ○	● ● ● ○	● ● ● ○
<b>Sun</b>	Outstanding thermal control in southern climates where less solar heat gain is desired.	● ● ● ○	● ● ● ●	● ○ ○ ○	● ● ● ○
<b>PassiveSun®</b>	Ideal for northern, passive solar construction applications where solar heat gain is desired.	● ● ● ○	● ○ ○ ○	● ● ● ○	● ● ● ○
<b>Triple-Pane with Low-E coatings on two surfaces</b>	Three panes of glass combine with either argon gas blend air or Low-E coatings to provide enhanced energy performance.	● ● ● ●	● ● ● ○	● ● ● ○	● ● ● ●
<b>Clear Dual-Pane</b>	High visibility with basic thermal performance.	● ○ ○ ○	○ ○ ○ ○	● ● ● ●	○ ○ ○ ○

Center of glass performance only. Ratings based on glass options as of March 2019. Visit [andersenwindows.com/energystar](http://andersenwindows.com/energystar) for ENERGY STAR® map and NFRC total unit performance data.



Additional glass options are also available. Visit [andersenwindows.com/glass](http://andersenwindows.com/glass) or see your Andersen supplier.

## HEATLOCK® TECHNOLOGY

Our HeatLock coating can increase the energy efficiency of any A-Series window or patio door with Low-E4 or SmartSun glass. Applied to the room-side glass surface, it reflects heat back into the home for improved performance.

## PATTERNED GLASS

Patterned glass lets in light while obscuring vision and adds a unique decorative touch to your home. Cascade and Reed patterns can be ordered with either a vertical or horizontal orientation.

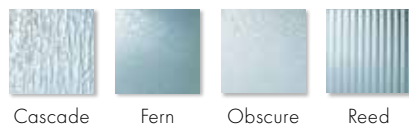

## STORMWATCH® PRODUCTS

Andersen® A-Series products are available with impact-resistant glass and structural upgrades to meet the tough building codes of hurricane-prone coastal areas. Visit [andersenwindows.com/coastal](http://andersenwindows.com/coastal) for more information and see your local building code official for specific requirements in your area.





## THE ENVIRONMENT HAS A BUSINESS PARTNER

Respect for the environment is nothing new at Andersen. For more than a century, it's been part of who we are. Our commitment to recycle and reclaim materials began simply because it was good business. Now it's part of our broader commitment to sustainability and responsible stewardship of all our resources. Andersen is committed to providing you with long-lasting,\* energy-efficient windows and doors. Visit [andersenwindows.com/sustainability](https://andersenwindows.com/sustainability) for more information.



Andersen makes windows and doors with options that make them ENERGY STAR® v. 6.0 certified throughout the U.S.



Andersen is a charter member of the **U.S. Green Building Council** and a strong supporter of its LEED® (Leadership in Energy and Environmental Design) National Green Building Standard rating system.



\*Visit [andersenwindows.com/warranty](https://andersenwindows.com/warranty) for details.  
All trademarks where denoted are marks of their respective owners.  
©2020 Andersen Corporation. All rights reserved. 02/20 Part #9066670



## 37982 — THERMAL SASH (SDL)

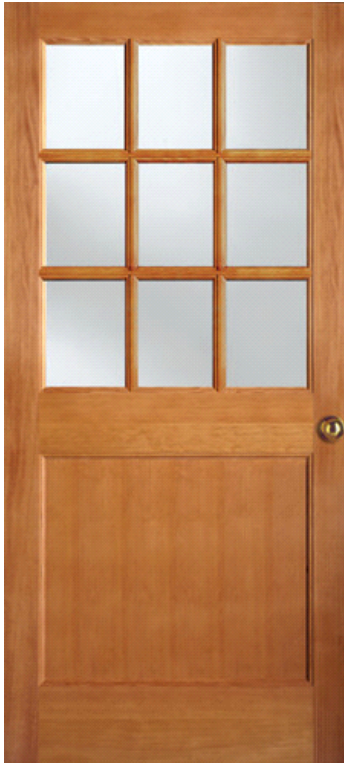

**SERIES:** Exterior French & Sash Doors

**TYPE:** Exterior French & Sash

**APPLICATIONS:** Can be used for a swing door, with barn track hardware, with pivot hardware, in a patio swing door or slider system and many other applications for the home's exterior.





**Construction Type:**

Engineered All-Wood Stiles and Rails with Dowel Pinned Stile/Rail Joinery

**Panels:** 3/4" VG Flat Panel

**Glass:** 3/4" Insulated Glazing

### STANDARD FEATURES

-  Any Wood Species
-  Virtually Any Size
-  Glass Options
-  Privacy Rating: 1

### DETAILED DRAWING

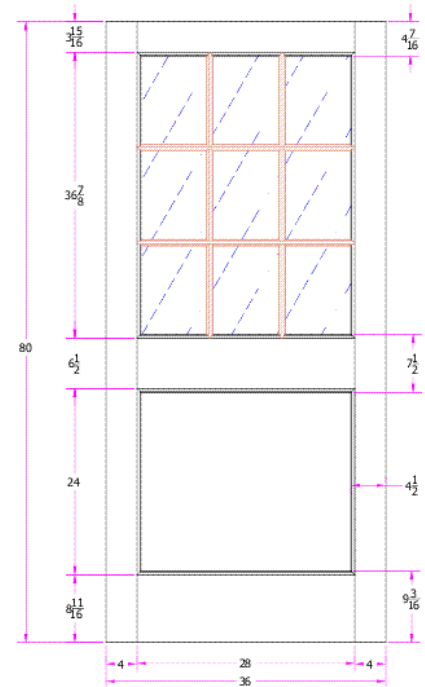

THIS DRAWING AND THE INFORMATION CONTAINED HEREIN IS PROPRIETARY TO

1 cm =

### DETAILS

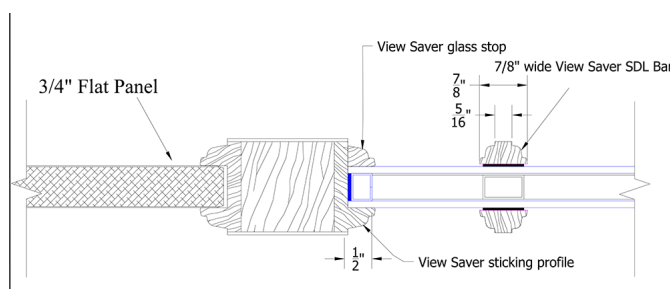

(Standard)



East Porch wall section